

IMPORTANT SAFETY NOTICES

PREVENTION OF PHYSICAL INJURY

1. Before disassembling or assembling parts of the printer and peripherals, make sure that the printer power cord is unplugged.
2. The wall outlet should be near the printer and easily accessible.
3. Note that some components of the printer are supplied with electrical voltage even if the main switch is turned off.
4. If any adjustment or operation check has to be made with exterior covers off or open while the main switch is turned on, keep hands away from electrified or mechanically driven components.

HEALTH SAFETY CONDITIONS

1. If you get ink in your eyes by accident, try to remove it with eye drops or flush with water as first aid. If unsuccessful, get medical attention.
2. If you ingest ink by accident, induce vomiting by sticking a finger down your throat or by giving soapy or strong salty water to drink.

OBSERVANCE OF ELECTRICAL SAFETY STANDARDS

1. The printer and its peripherals must be installed and maintained by a customer service representative who has completed the training course on those models.
2. The RAM board has a lithium battery which can explode if handled incorrectly. Replace only with the same type of RAM board. Do not recharge or burn this battery. Used RAM boards must be handled in accordance with local regulations.

SAFETY AND ECOLOGICAL NOTES FOR DISPOSAL

1. Dispose of replaced parts in accordance with local regulations.
2. Used ink and masters should be disposed of in an environmentally safe manner and in accordance with local regulations.
3. When keeping used lithium batteries (from the main control boards) in order to dispose of them later, do not store more than 100 batteries (from the main control boards) per sealed box. Storing larger numbers or not sealing them apart may lead to chemical reactions and heat build-up.

General Remarks

Each model code used in this manual represents the following models.

Model Code	RICOH Model	NRG Model	A.B.Dick Model	SAVIN Model
C215	VT2005	5323		
C216	VT2105	CP325/1250/5325		
C224	VT2200	CP327/1252/5327	6530	3200DNP
C226	VT2250/40	CP329(L)/1254(L)/5329(L)	6560	3250DNP

SECTION 1

**OVERALL MACHINE
INFORMATION**

1. SPECIFICATIONS

Configuration:	Desktop
Master processing:	Digital
Printing process:	Full automatic one-drum stencil system
Original type:	Sheet/Book
Platen mode:	Document Size: Smaller than 257 x 364 mm [10.2" x 14.4"] Thickness: Less than 30 mm Weight: Less than 5 kg
ADF mode:	Document Size Length: 105 - 364 mm [4.1" - 16.5"] Width: 148 - 364 mm [5.8" - 16.5"] Thickness: 0.05 to 0.2 mm [2 to 8 mils] (equivalent to 50 - 90 g/m ²) 0.04 to 0.4 mm [1.6 to 16 mils], manually assisted (equivalent to 40 - 120 g/m ²) Document Feed Automatic feed, face up ADF Capacity 30 sheets (using 20 lb paper)
Scanning method:	Contact image sensor, with xenon lamp
Maximum scan width	256 mm [10.1"] ± 0.25%

Reproduction ratios:	U.S.A. Version	Other Versions
	Full Size	100%
	Reduction	100%
		71%
		82%
		87%
		93%
	Enlargement	121%
		115%
		122%
		141%
Image mode:	Letter, Photo, Letter/Photo	
Color printing:	Drum unit replacement system	
Master feed/eject:	Roll master automatic feed/eject	
Printing area:	Maximum: 250 mm x 355 mm (9.8" x 14.0") at 20°C/ 65 % RH. (210 mm x 288 mm for the A4 drum model)	
Leading edge margin:	5 ± 3 mm at the "0" position	
Print paper size:	Minimum: 90 mm x 148 mm (3.6" x 5.9") Maximum: 297 mm x 432 mm (11.6" x 17.0")	
Print paper weight:	47.1 g/m ² to 209.3 g/m ² (12.5 lb to 55.6 lb)	
Printing speed:	60, 75, 90, 105, 120 sheets/minute (5 steps)	
First copy time:	Platen mode: Less than 26 seconds (B4 paper) Less than 25 seconds (A4 paper) ADF mode: Less than 29 seconds (B4 paper) Less than 28 seconds (A4 paper)	
Second copy time:	Platen mode: Less than 28 seconds (B4 paper) Less than 27 seconds (A4 paper) ADF mode: Less than 32 seconds (B4 paper) Less than 31 seconds (A4 paper)	
Paper feed table capacity:	1000 sheets (66.3 g/m ² /17.6 lb)	
Paper delivery table capacity:	1000 sheets (66.3 g/m ² /17.6 lb) (800 sheets when the small guide plates are used.)	

Power source:	110/120 V, 60 Hz	4.5 A
	220/240 V, 50/60 Hz	2.7 A
Maximum power consumption:	110/120 V version:	325 W
	220/240 V version:	340 W
Weight:	95 kg (209.4 lb)	
Dimensions: (W x D x H)	Trays closed: 685 mm x 625 mm x 620 mm (27.0" x 24.6" x 24.4")	
	With ADF: 685 mm x 625 mm x 670 mm (27.0" x 24.6" x 26.4")	
	Trays open: 1285 mm x 625 mm x 620 mm (50.6" x 24.6" x 24.4")	
	With ADF: (1285 mm x 625 mm x 670 mm (50.6" x 24.6" x 26.4"))	
Pixel density:	300 dots/inch	
Master eject box capacity:	70 masters (Normal conditions) 60 masters (10°C/30%RH)	
Paper feeding:	Friction roller/center separation system	
Feed table side plate width settings:	88 mm to 330 mm (3.46" to 12.99")	
Paper feed roller pressure:	Normal position	300 g
	Thick paper position	400 g
Separation roller pressure:	Normal position	180 g
	Weak position	70 g
Side registration:	± 10 mm (manual)	
Vertical registration:	± 20 mm (mechanical)	
Ink supply:	Automatic ink supply system	
Press roller pressure:	10 ± 0.3 kg	
Paper delivery:	Air knife/vacuum delivery	

Delivery side plate width settings: 90 mm to 320 mm (3.54" to 12.6")

Print counter: 7 digits

Master counter: 6 digits (Option)

Supplies:

Master for B4 model

Thermal master	280 mm width
Master roll	257 masters/roll
Roll diameter	130 mm
Max run length	2,000 prints

Master for A4 model

Thermal master	240 mm width
Master roll	290 masters/roll
Roll diameter	130 mm
Max run length	2,000 prints

Ink colors: (600 ml/pack)	Black, Red, Blue, Green, Brown Yellow, Purple, Navy, Maroon, Orange, Teal
------------------------------	--

2. GUIDE TO COMPONENTS AND THEIR FUNCTION

2.1 MACHINE EXTERIOR

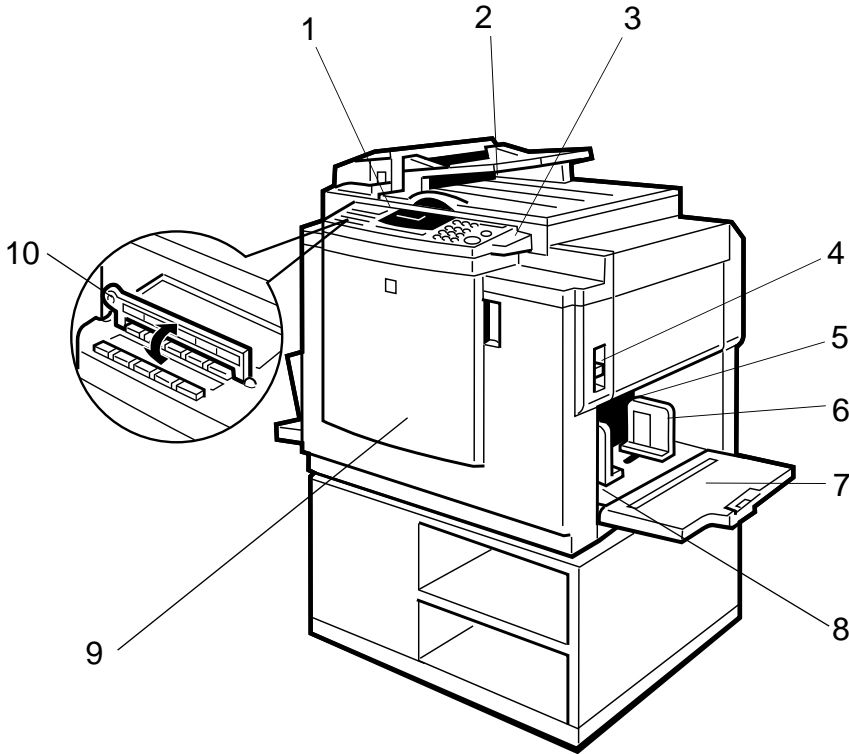

- 1. Operation panel** Operator controls and indicators are located here.
- 2. Platen cover** Lower this cover over an original before printing.
- 3. Original table release lever** Use to open the original table unit when installing the master.
- 4. Feed roller pressure lever** Use to adjust the contact pressure of the paper feed roller according to paper thickness.
- 5. Separation roller pressure lever** Use to adjust the separation roller pressure to prevent double feed.
- 6. Paper feed side plates** Use to prevent paper skew.
- 7. Paper feed table** Set paper on this table for printing.
- 8. Side plate fine adjusting dial** Use to shift the paper feed table sideways.
- 9. Front cover** Open to access to the inside of the machine.
- 10. Plate** Flip over when you use One Touch Class function.

2.2 MACHINE INTERIOR

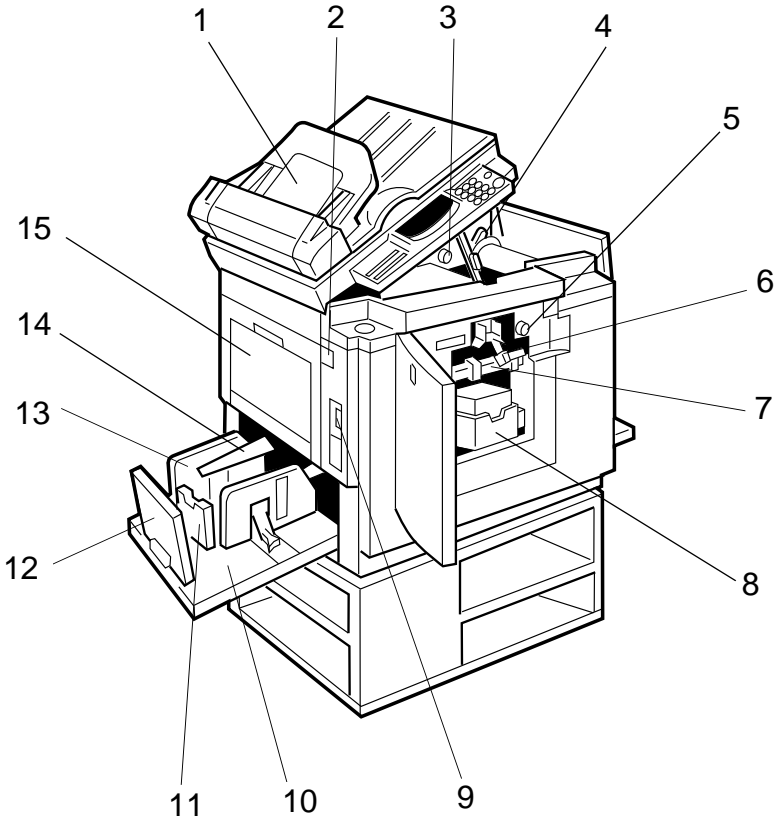

- 1. Document feeder (Option)** Original inserted into the document feeder are individually and automatically fed onto and removed from the exposure glass.
- 2. Master eject unit open button** Press to remove misfed paper or a misfed master.
- 3. Master cut button** Press this button to cut the master leading edge after installing a new master roll.
- 4. Pressure release lever** Use to install the master roll.
- 5. Drum rotation button** Press to rotate the drum unit.
- 6. Drum unit lock lever** Lift to unlock and pull out the drum unit.
- 7. Drum unit** The master is wrapped around this unit.
- 8. Ink holder** Set the ink cartridge in this holder.
- 9. Main switch** Use to turn the power on or off.
- 10. Paper delivery table** Completed prints are delivered here.
- 11. Small size paper delivery end plate** Use to align the leading edge of prints that are A4, 8 1/2" x 11" or smaller.
- 12. Paper delivery end plate** Use to align the leading edge of prints larger than A4, 8 1/2" x 11".
- 13. Paper delivery side plate** Use to align the prints on the paper delivery table.
- 14. Wing guides** When printing on thin or small size paper, lift these guides.
- 15. Master eject container cover** Open when removing the master eject box.

3. OPERATION PANEL

3.1 KEYS

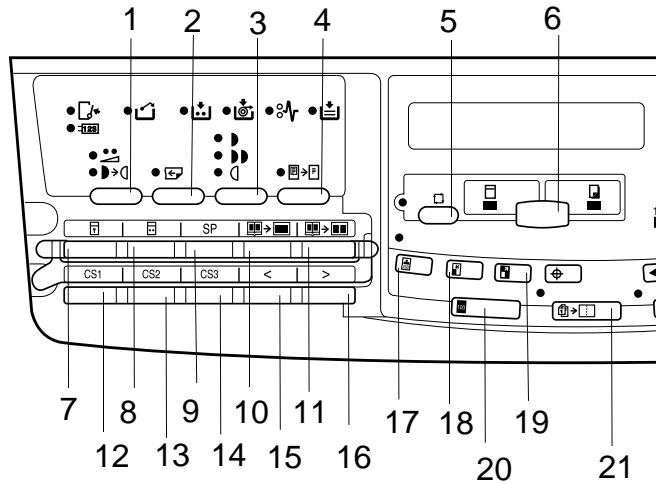

- | | |
|--|---|
| 1. Economy/Tint key | 11. Edge Erase/Center Erase key |
| 2. Skip Feed key | 12. 13. 14. CS mode keys |
| 3. Image Density key | 15. 16. Scroll keys |
| 4. Paste Shadow Erase key | Press to select size and direction of paper or original in Edge Erase/Center Erase and Edge Erase function. |
| 5. Auto Cycle key | Press to select the mode in Service Program mode. |
| 6. Master Making/Print key | |
| Press to select Master Making or Print mode. | |
| 7. Security key | 17. Type of Original key |
| 8. Quality Start key | 18. Reduce key |
| 9. SP mode key | 19. Enlarge key |
| 10. Edge Erase key | |

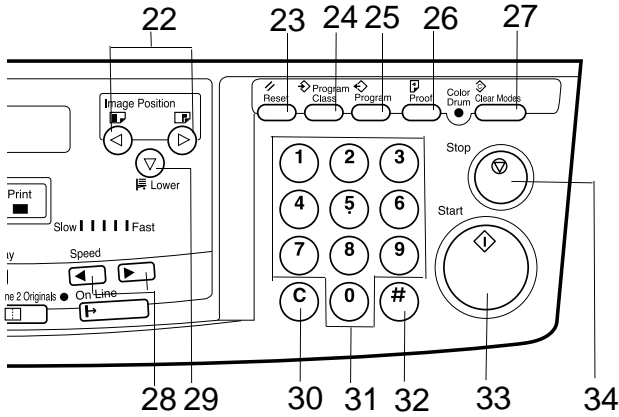

- | | |
|---|--|
| <p>20. Full Size key
Press to make full size prints.</p> <p>21. Combine 2 Originals key</p> <p>22. Image Position keys</p> <p>23. Reset key
Press to reset the error indicators.</p> <p>24. Program Class key</p> <p>25. Program key</p> <p>26. Proof key
Press to make proof prints.</p> <p>27. Clear Modes key
Press to cancel all previously entered settings.</p> <p>28. Speed keys</p> | <p>29. Lower key
Press to lower the paper feed table.</p> <p>30. Clear key
Press to change the number set.</p> <p>31. Number keys
Press to enter the number of prints and data.</p> <p>32. Enter key
Press to input data into memory.</p> <p>33. Start key
Press to start making of a master or printing.</p> <p>34. Stop key
Press to stop the machine operation.</p> |
|---|--|

3.2 INDICATORS

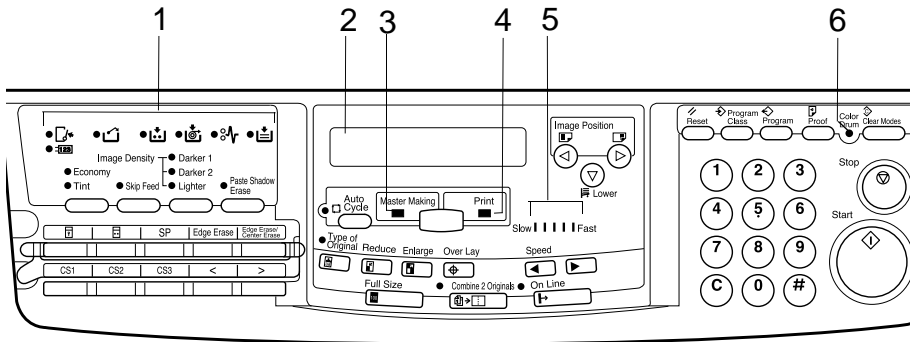

1. Error indicators

These indicators are lit when a non-standard condition occurs within the machine.

2. Guidance Display

Press to stop the machine operation.

3. Master Making indicator

This indicator is lit when Master Making mode is selected.

4. Print indicator

This indicator is lit when Print mode is selected.

5. Speed indicators

These indicators show the printing speed that is selected.

6. Color Drum indicator

This indicator is lit when the optional color drum unit is set.

4. PRINTING PROCESS

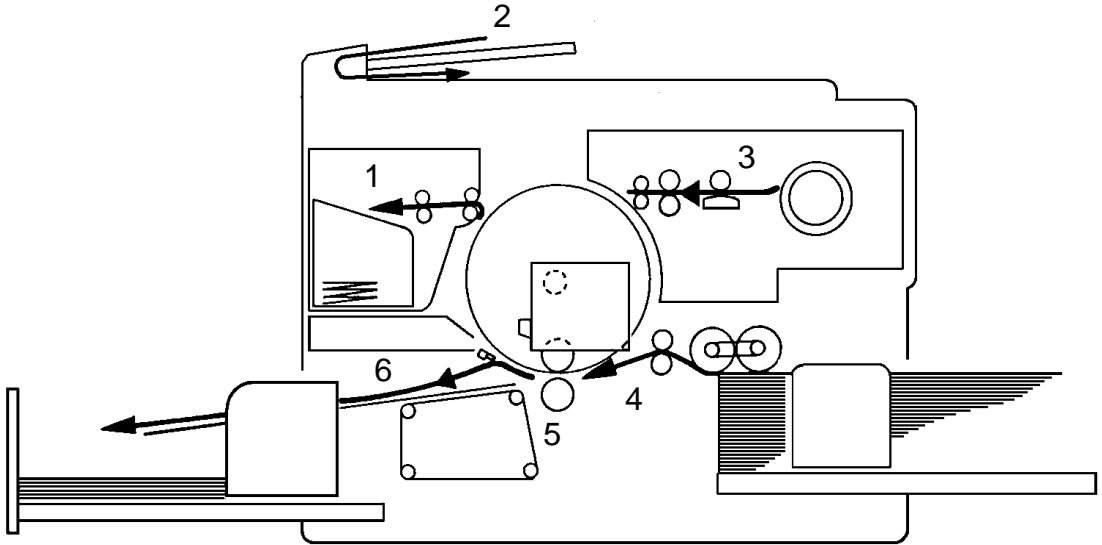

1. Master Ejecting: Eject the used master wrapped around the drum into the master eject box.
2. Scanning: Scan the original image by Contact Image Sensor while feeding the original.
3. Master Feeding: Convert the image signal into the digital signal and send it to the thermal head to make holes on the surface of the master and then, set the master around the drum.
4. Paper Feeding: Send paper to the drum section by using center separation system consisting of the separation plate and separation roller.
5. Printing: Press the paper fed from the paper feed section to the drum to transfer the ink through drum screen and the master.
6. Paper Delivering: Peel the printed paper with the Exit Pawl and Air knife and eject the paper onto the paper delivery table.

5. ELECTRICAL COMPONENTS LAYOUT

5.1 ADF AND SCANNER

Overall Information

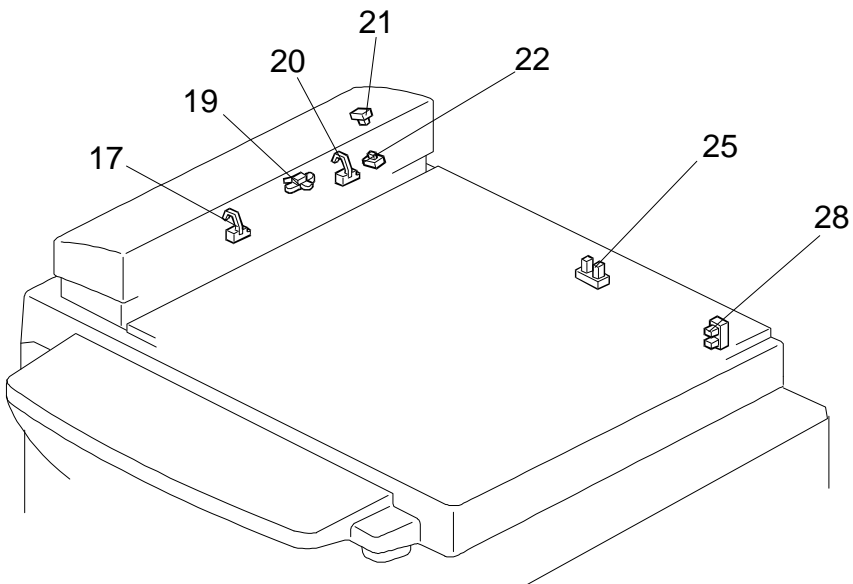
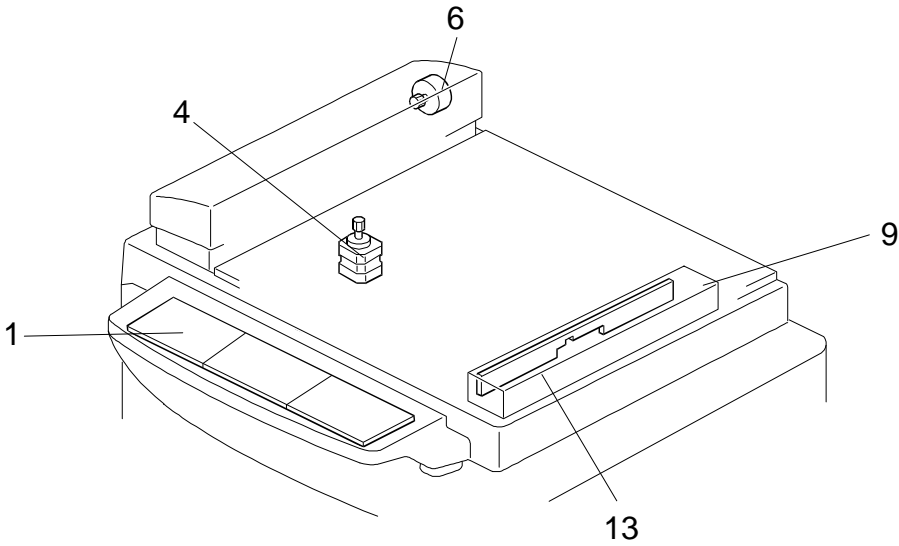

Table

INDEX NO.	NAME	FUNCTION
Printed Circuit Board		
1	OPU (Operation Panel Unit)	This board controls the operation panel.
9	Contact Image Sensor and Xenon Lamp	This sensor reads and converts the light reflected from the document into an analog video signal. It uses an RMLA (Roof Mirror Lens Array) sensor unit. The xenon lamp which illuminates the document is contained in this unit.
Motors		
6	ADF Motor	This stepper motor drives the scanner.
4	Scanner Motor	This stepper motor drives the book scanner.
Sensors and Switches		
17	Document Sensor	This detects the presence of a document in the feeder.
19	Scan Line Sensor	This detects when a page is approaching the auto shading position.
20	Not used	
21	ADF Cover Switch	This detects whether the ADF cover is open or closed.
28	Scanner Home Position Sensor	This detects when the image sensor is at home position.
25	Platen Cover Sensor	This detects whether the platen cover is open or closed.
22	ADF Switch	This detects whether the ADF unit is open or closed.
Others		
13	Lamp Stabilizer	This supplies power to the xenon lamp.

5.2 MAIN BODY

Overall Information

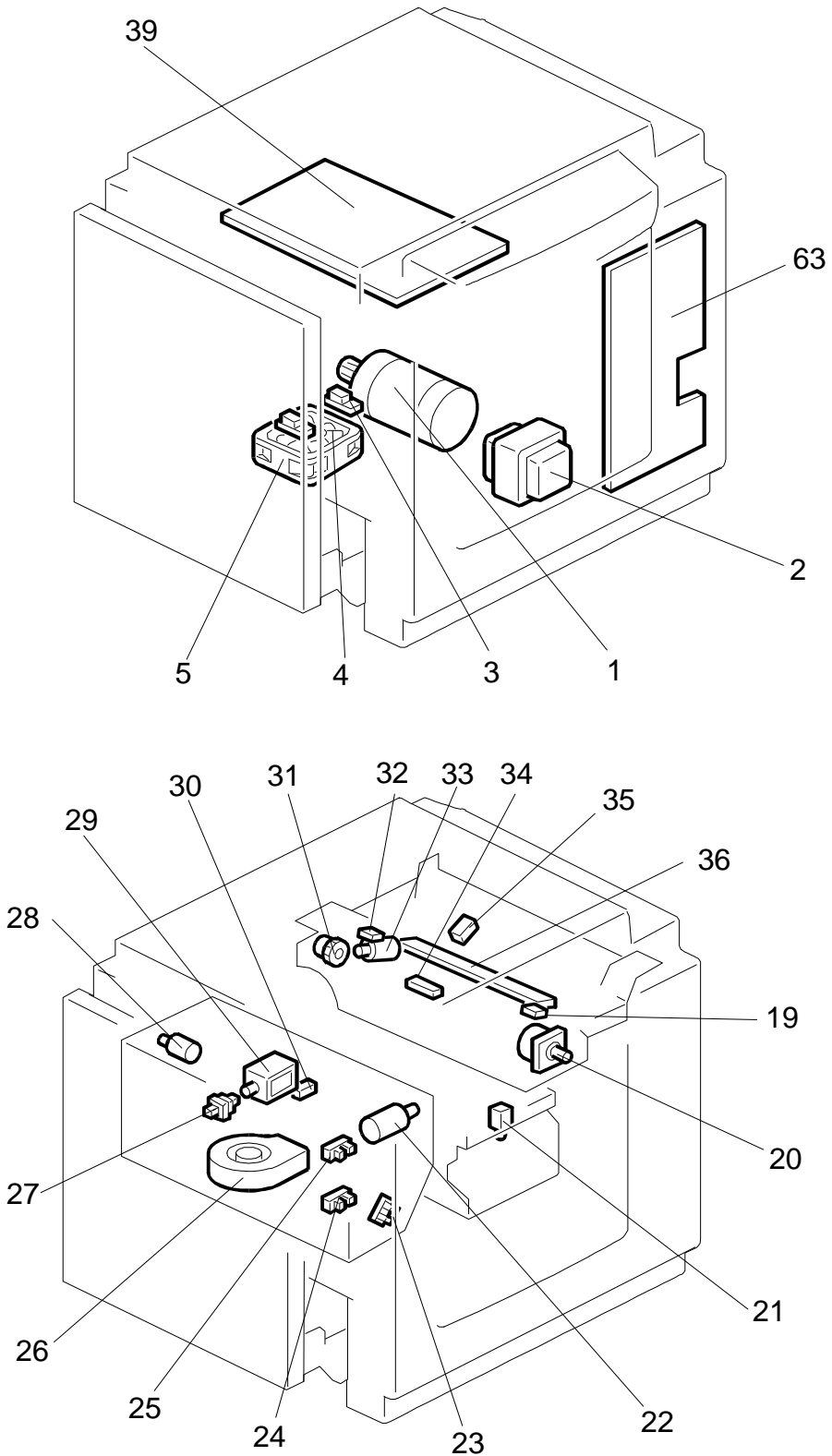

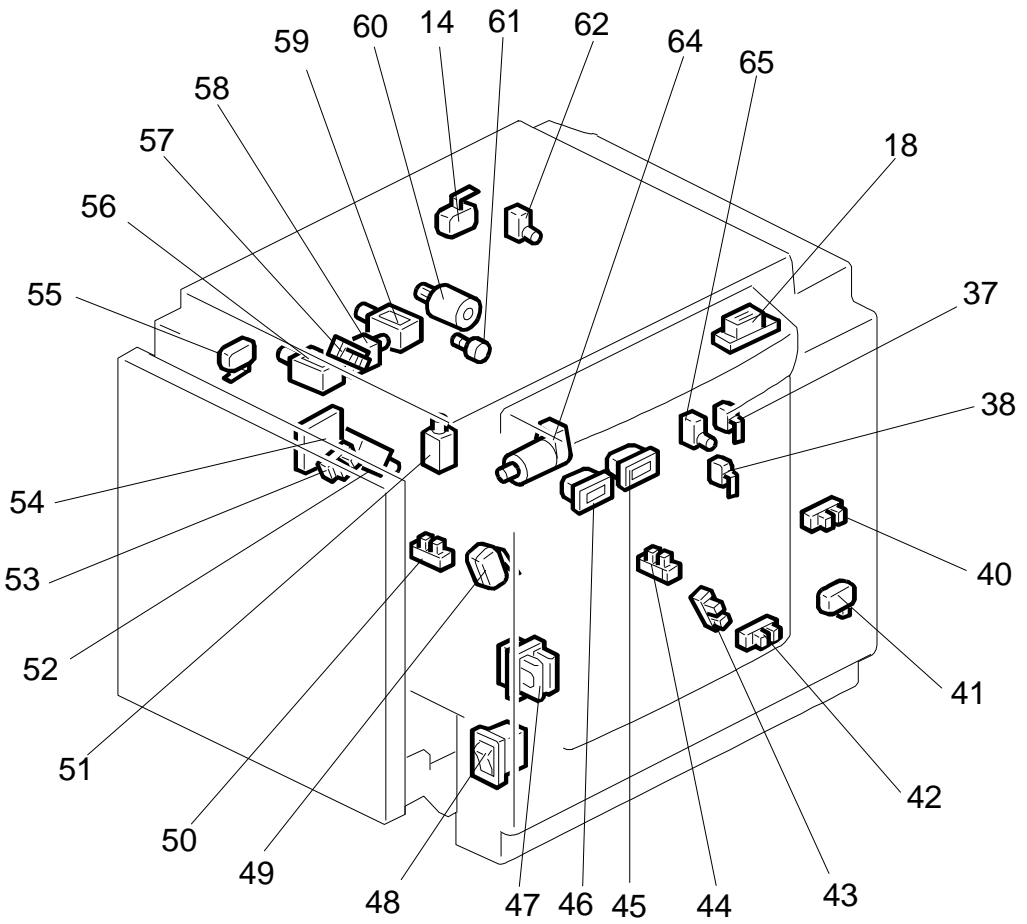

Table

INDEX No.	NAME	FUNCTION
Motors		
1	Main Motor	Drives paper feed, drum, printing and paper delivery unit components.
4	Vacuum Motor	Provides suction so that paper is held firmly on the transport belt.
20	Master Feed Motor	Feeds the master to the drum.
22	Pressure Plate Motor	Raises and lowers the pressure plate.
26	Air Knife Motor	Rotates the fan to provide air to separate the paper leading edge from the drum.
28	Master Eject Motor	Sends used masters into the master eject box.
33	Cutter Motor	Cuts the master.
60	Image Shift Motor	Changes the timing between the paper feed roller and the drum to adjust the vertical image position.
64	Paper Table Drive Motor	Raises and lowers the paper table.
Solenoids		
21	Ink Supply Solenoid	Releases the spring clutch to activate the ink supply pump.
29	Master Eject Solenoid	Opens the master clamp to eject the master.
51	Paper Feed Solenoid	Releases the paper feed sector gear to rotate the paper feed roller.
52	Printing Pressure Solenoid	Moves the press roller against the drum.
56	Master Eject Clamper Solenoid	Opens the master clamp to eject the master.
58	Drum Lock Solenoid	Prevents removal of the drum unit when the drum is not at the home position.
59	Master Feed Clamper Solenoid	Opens the master clamp to eject the master.
Switches		
14	Scanner Unit Safety Switch	Check whether the scanner unit is set correctly or not.
18	Plotter Cover Safety Switch	Check whether the cover on the plotter unit is closed correctly or not.
19	Left Cutter Switch	Detects when the cutter position is at the far left.
27	Master Eject Box Switch	Checks whether the master eject box is installed correctly or not.
32	Right Cutter Switch	Detects when the cutter position is at the far right.
37	Front Door Safety Switch	Checks whether the front door is set correctly or not.
38	Drum Safety Switch	Checks whether the drum unit is set correctly or not.
41	Paper Table Safety Switch	Checks whether the paper table is opened or not.

INDEX No.	NAME	FUNCTION
47	Test Switch	Releases the cover safety functions. (NOTE:)
48	Main Switch	Turns the power on or off.
49	Master Eject Unit Safety Switch (220V machines only)	Checks whether the master eject unit is closed correctly or not. Cuts the ac power.
55	Master Eject Unit Safety Switch (115V machines only)	
62	Master Cutter Switch	Informs the CPU to cut the master paper leading edge.
65	Drum Rotation Switch	Informs the CPU to rotate the main motor at 10 rpm.
Sensors		
3	1st Paper Exit Sensor	Detects misfeeds.
5	2nd Paper Exit Sensor	Detects misfeeds.
23	Lower Pressure Plate Sensor	Informs the CPU if the pressure plate is at the lower limit position.
24	Full Master Box Sensor	Informs the CPU if the master eject box is full of used masters.
25	Upper Pressure Plate Sensor	Informs the CPU if the pressure plate is at the upper limit position.
30	Master Eject Sensor	Detects master eject jams.
34	Master Buckle Sensor	Detects master buckling.
35	Master End Sensor	Informs the CPU when the plotter unit runs out of master roll.
40	Paper Table Height Sensor	Detects when the paper table reaches the paper feed position.
42	Paper Table Lower Limit Sensor	Detects when the paper table reaches the lowest position.
43	Printing Pressure Sensor	Informs the CPU when printing pressure is applied.
44	Paper End Sensor	Informs the CPU when the paper table runs out of paper.
50	Drum Rotation Sensor	Supplies timing pulses to the main board.
53	2nd Drum Position Sensor	Checks the position of the drum.
57	1st Drum Position Sensor	Checks the position of the drum.
Printed Circuit Board		
39	Main Control PCB	Controls all machine functions both directly and through other boards.

INDEX No.	NAME	FUNCTION
54	Ink Detection PCB	Checks if the ink is present in the drum.
63	Power Supply PCB	Rectifies 100 V ac input and supplies dc voltage.
Counters		
45	Copy Counter	Keeps track of the total number of copies made.
46	Master Counter	Keeps track of the total number of masters made.
Others		
2	Transformer	Steps down the wall voltage.
31	Reverse Roller Clutch	Transfers master feed motor rotation to the reverse roller at proper timing.
36	Thermal Head	Burns the image onto the master.
61	Encoder	Converts 16 image positions to 4 bit data.

- NOTE:** 1) The Master Eject Unit Safety Switch in the 220 V machines cannot be disabled by this test switch.
- 2) When you use this test switch, be sure to return it to home position after servicing in order to recover the cover safety functions.

6. MECHANICAL COMPONENT LAYOUT

6.1 ADF AND SCANNER

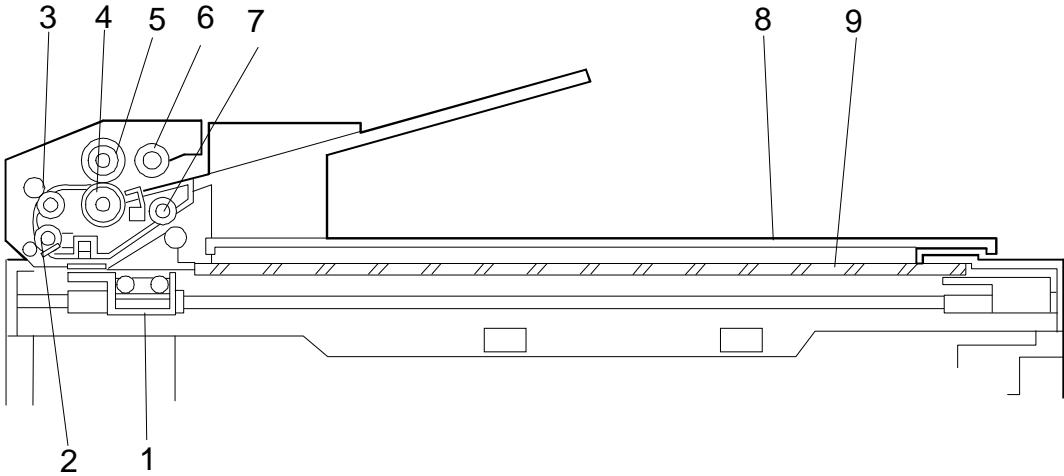

No.	Name	Description
1	Scanner	Contains a contact image sensor and a xenon lamp driver.
2	R1 Roller	Feeds the document through the scanner.
3	R0 Roller	Feeds the document into the scanner.
4	Separation roller	Prevents more than one sheet from feeding into the scanner.
5	Document Feed Roller	Feeds the document into the scanner.
6	Pick-up Roller	Picks up pages of the document from the document table one at a time.
7	R2 Roller	Feeds the document through the scanner.
8	Platen Cover	This covers the original which was placed on the exposure glass.
9	Exposure Glass	Book scanner reads the original on it.

6.2 MECHANICAL COMPONENT LAYOUT

Overall Information

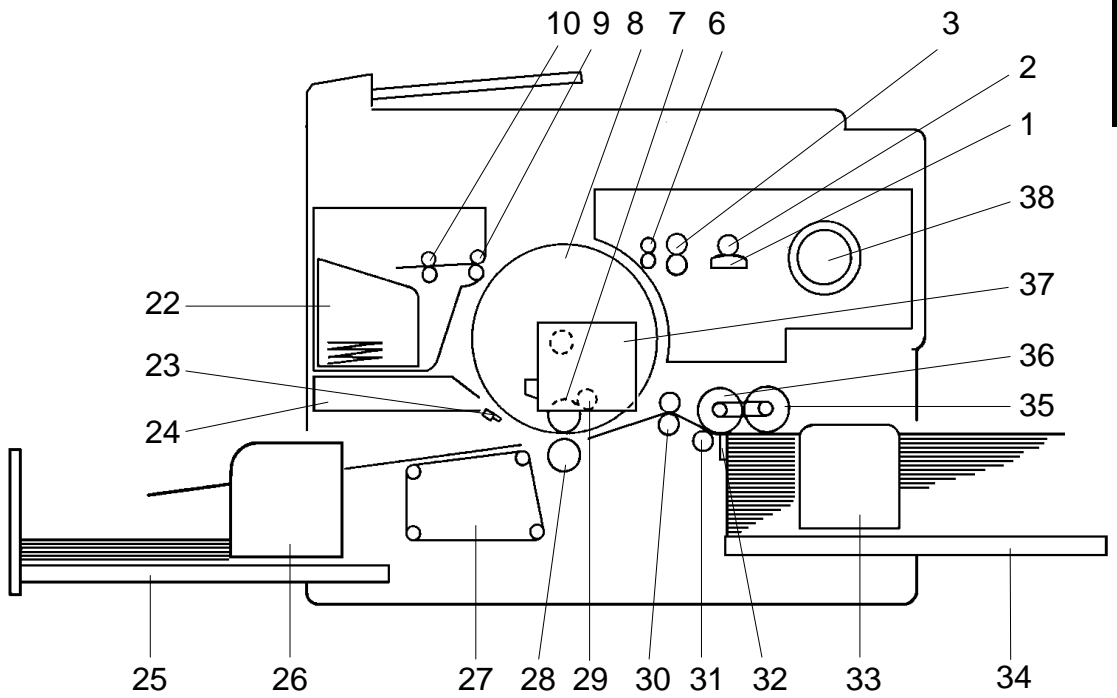

- | | |
|--------------------------|-----------------------------|
| 1. Thermal Head | 27. Vacuum Unit |
| 2. Platen Roller | 28. Press Roller |
| 3. Master Feed Roller | 29. Doctor Roller |
| 6. Reverse Roller | 30. 2nd Feed Roller |
| 7. Ink Roller | 31. Lower Separation Roller |
| 8. Drum Unit | 32. Separation Plate |
| 9. 1st Eject Roller | 33. Paper Feed Side Plate |
| 10. 2nd Eject Roller | 34. Paper Feed Table |
| 22. Master Eject Box | 35. Paper Feed Roller |
| 23. Exit Pawl | 36. Upper Separation Roller |
| 24. Air Knife | 37. Ink Holder |
| 25. Delivery Table | 38. Master Spool |
| 26. Delivery Guide Plate | |

7. DIFFERENCES BETWEEN MODELS

7.1 C226 AND C224

No.	Item	Remarks
1.	ADF, Scanner, and Operation Panel	<p>These units are commonly used in our facsimile products. The C226 model uses a book type scanner. The C224 model does not have this feature. The contact image sensor removes the necessity of complicated adjustments needed for a CCD scanner.</p> <p>A half-tone processor is used for image processing. This processor is similar to those in higher level models. It produces better copy quality half-tone images in Photo and Letter/Photo modes.</p>
2.	Paper Delivery Table	<div data-bbox="589 721 1027 1044" data-label="Image"> </div> <p>The C226 model uses a new paper delivery table. This table has newly added small guide plates [A] on each front and rear side fence. The guide plates stack the prints more evenly. The small guide plates [B], on the bottom of each side fence keep the prints aligned in the center of the table while the copies are stacked. Also, the paper stack capacity has been increased from 500 sheets to 1000 sheets.</p> <div data-bbox="641 1395 1002 1689" data-label="Image"> </div> <p>Due to the the new paper delivery table design, a new auxiliary bracket [C] has been added for optional TAPE MAKER installation. For details, refer to the "Tape Maker Installation" section.</p>

No.	Item	Remarks
		<p>NOTE:</p> <p>1) The small upper guide plates are needed when thin or normal paper (80g/m² or 20 lb. and thinner paper) is used. The guide plate is not needed for thicker paper. If the paper is too thick, it may be caught by the upper guide plates. (Thick paper can be stacked evenly without the upper guide plates.)</p> <p>2) When the small upper guide plates are used, the paper delivery table's stack capacity reduces to about 750 sheets (depending on paper type). Close the guide plates to achieve the maximum paper stack capacity.</p> <p>3) The optional TAPE MAKER works with up to 500 sheets (depending on paper type).</p>
3.	Main Control PCB	<p>The C224 model's A/D Conversion PCB is not used. The function is now included in the Main Control PCB, which is located beneath the scanner unit. Since the Main Control PCB was moved from the operational side, the Power Supply PCB was also moved from the non-operation side of the machine to where the Main Control PCB was located in the C224 model.</p>

No.	Item	Remarks
4.	New Functions in Operation	<p>The following functions were not used in the C224 model:</p> <ul style="list-style-type: none"> - CS Mode - SP Mode (User Accessible) - Paste Shadow Erase Mode (Unique to the C226 model) - One Touch Class Mode (Unique to the C226 model) - Tint Mode (Unique to the C226 model) - Program Mode - Letter/Photo Mode (In addition to the Letter and Photo modes.) - Quality Start Mode: See NOTE 1 - Edge Erase Mode: See NOTE 2 - Edge Erase / Center Erase Mode: See NOTE 2 <p>NOTE:</p> <p>1) In the Quality Start mode, after the master making process, one extra print (this can be set by the operator from 0 to 3 prints) is made at the lowest printing speed (20 cpm). The trial print is made in the same way as other models. As the default setting, two extra prints are made in the Quality Start mode. The Quality Start mode is also used in some other models, however, this method is unique to the C226 model.</p>

SECTION 2
SECTIONAL DESCRIPTION

1. ORIGINAL FEED SECTION

1.1 BOOK SCANNER OVERVIEW

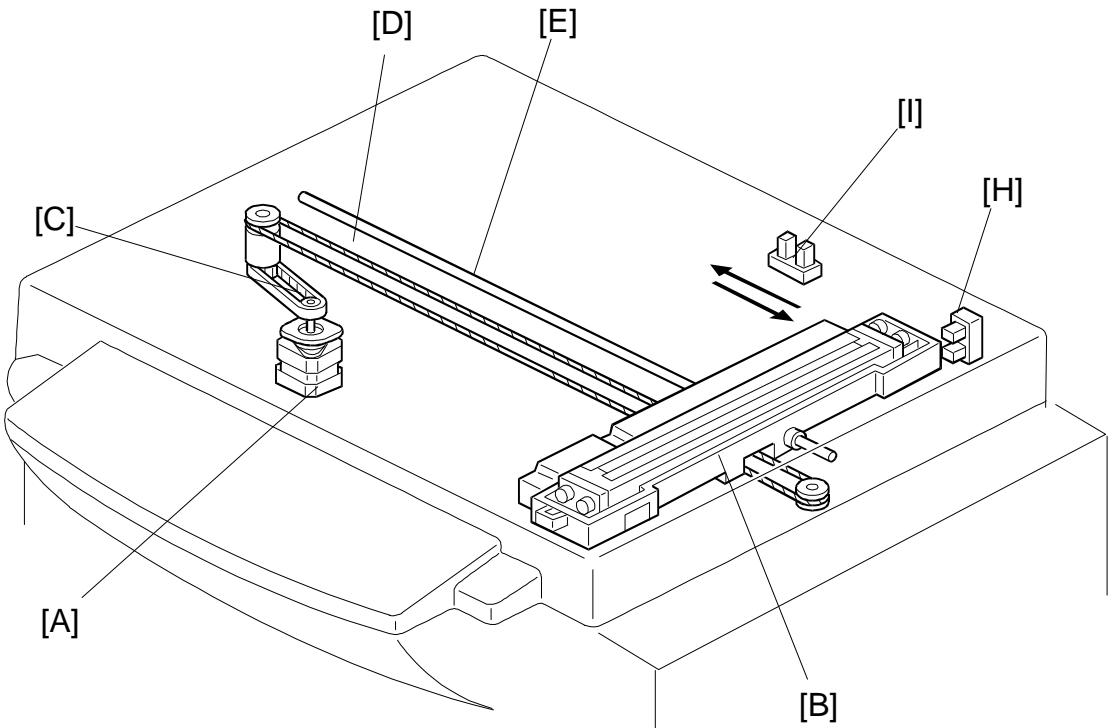

The scanner motor [A] drives the scanner [B] through the timing belt [C] and drive wire [D]. The shaft [E] guides scanner movement in the sub-scan direction. Inside the scanner [B] are a contact image sensor (containing a sensor element and xenon lamp) and a xenon lamp driver.

The scanner [B] consists of a contact image sensor and a xenon lamp driver.

The scanner home position sensor [H] allows the scanner return to the same position after scanning.

The platen cover switch [I] detects if the cover is opened or not.

1.2 ADF OVERVIEW

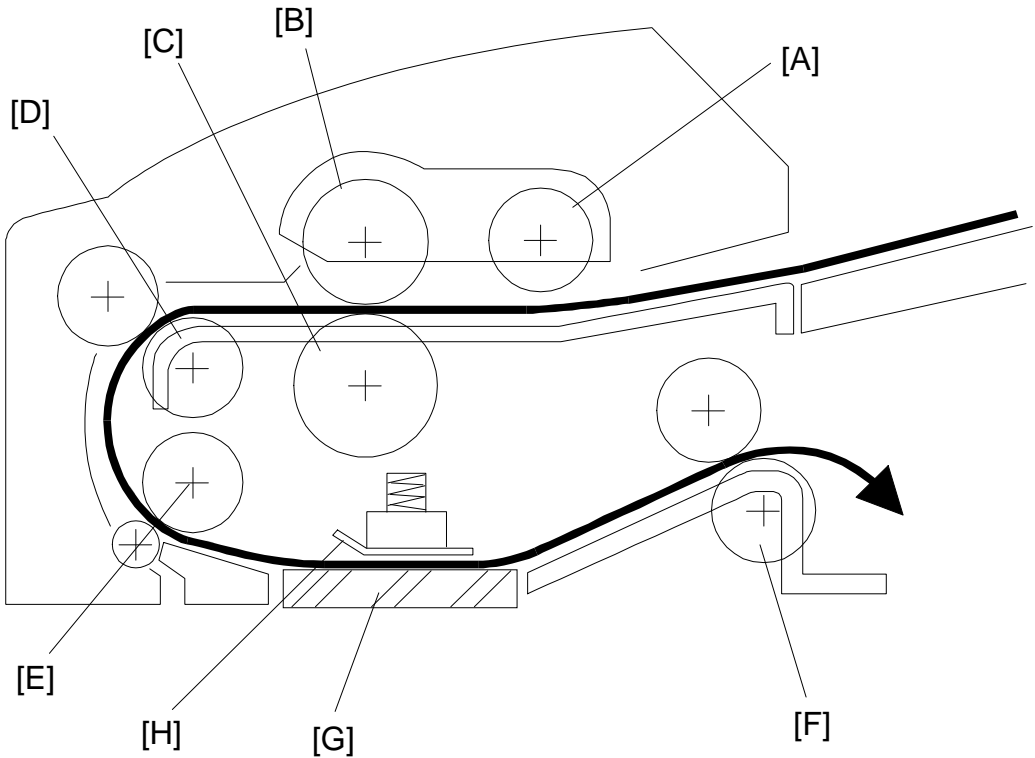

The sheet through type ADF feeds the document from the top page of the document stack on the table.

The pick-up [A] and feed roller [B] feed the original into the scanner, and the separation roller [C] helps to feed one sheet at a time. Then, the R0 [D], R1 [E], and R2 [F] rollers feed the document through the scanner.

At the time of scanning the document, the scanner moves down to the scanning position under the exposure glass [G]. The shading plate [H] pushes the document to the exposure glass at the scan line, so that the document is within the image sensor's range of focus.

After scanning, the ADF feeds out the document onto the platen cover, and the scanner moves back to its home position at the right end of the scanner.

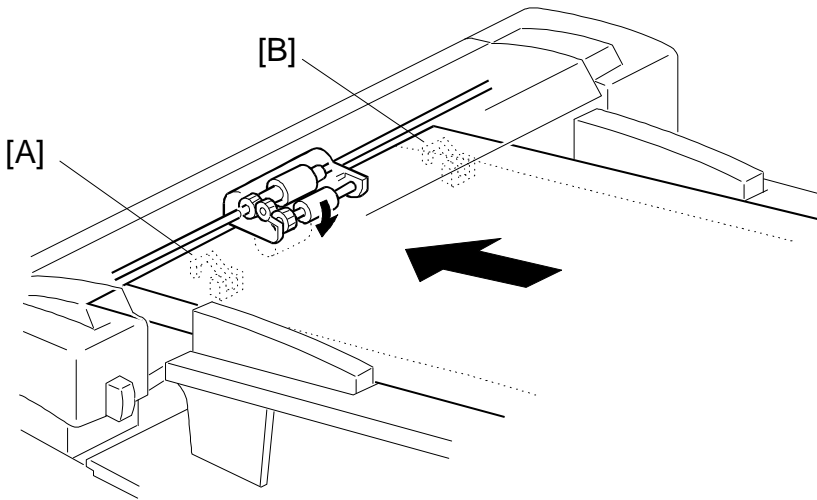

The document sensor [A] detects documents when they are set in the ADF. The sensor [B] is not used although it exists to use this unit for another product commonly.

1.3 CONTACT IMAGE SENSOR

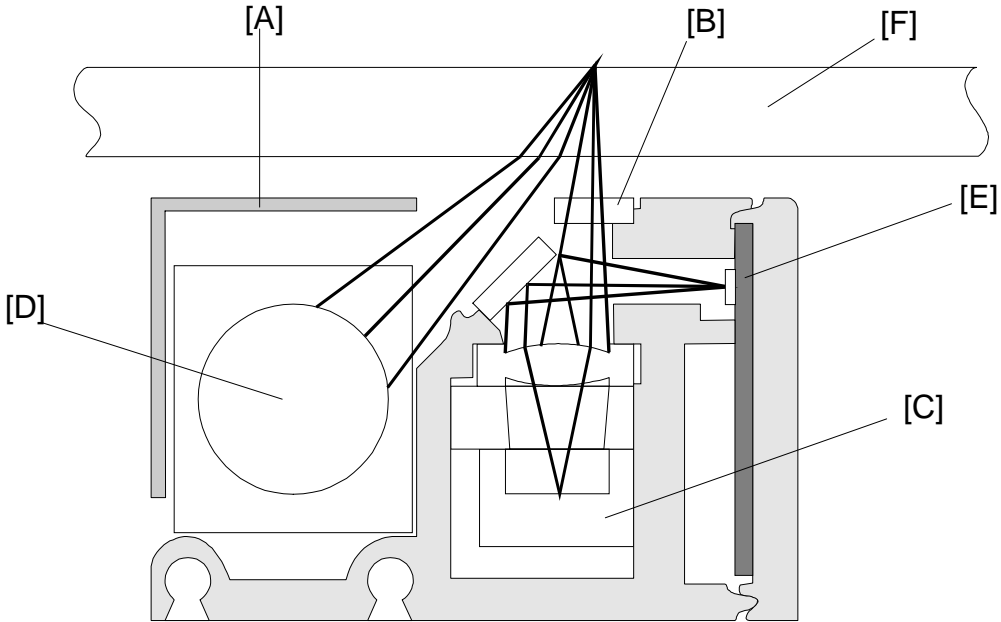

The contact image sensor (CIS) assembly [A] consists of an exposure glass [B], a roof mirror lens array [C], a xenon lamp [D], and an image sensor [E]. The CIS moves under the exposure glass when scanning a book original, or stays at the ADF scan line when scanning a sheet original using the ADF.

The image sensor is a row of 4096 photosensitive elements (B4 width x 16 dots/mm). The roof mirror lens array focuses the light reflected from the document onto the image sensor.

Because of the short optical path inside the CIS, the focal depth is much shorter than for a CCD type scanner. Because of this, two springs at each end of the CIS push it against the exposure glass [F], so that the distance from the original is kept the same all the time. However in book scanning mode, if the original is out of the CIS's focal range, the scanned image may get darker.

Because the analog output signal is a sawtooth waveform, data sampling timing should be adjusted whenever a new CIS is installed in the machine.

1.4 DRIVE MECHANISM

1. Book Scanner

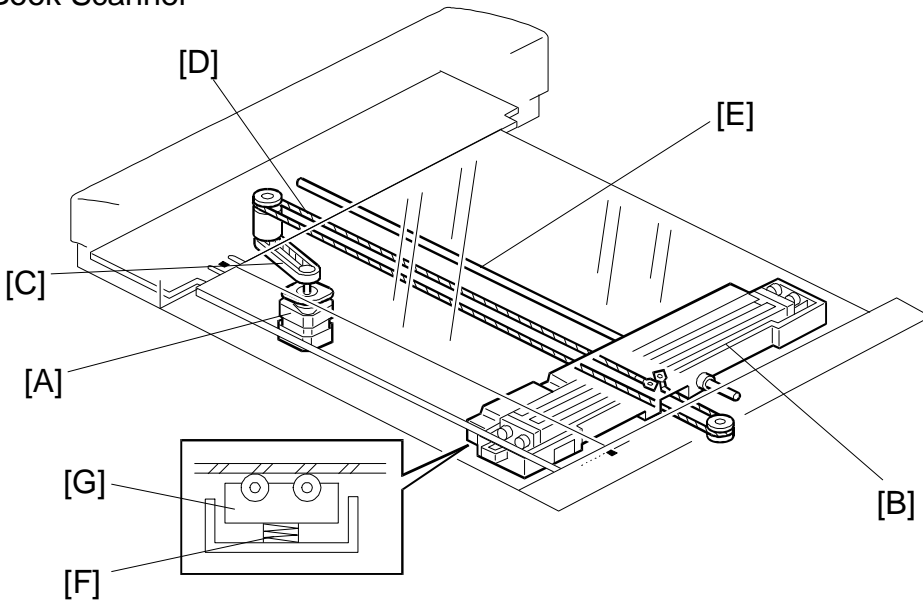

The book scanner motor [A] drives the scanner [B] through the timing belt [C] and drive wire [D]. The scanner moves along the guide shaft [E].

The spring [F] pushes up the contact image sensor [G] to the exposure glass, so that the distance from the image sensor to the exposure glass surface is constant during scanning.

2. ADF

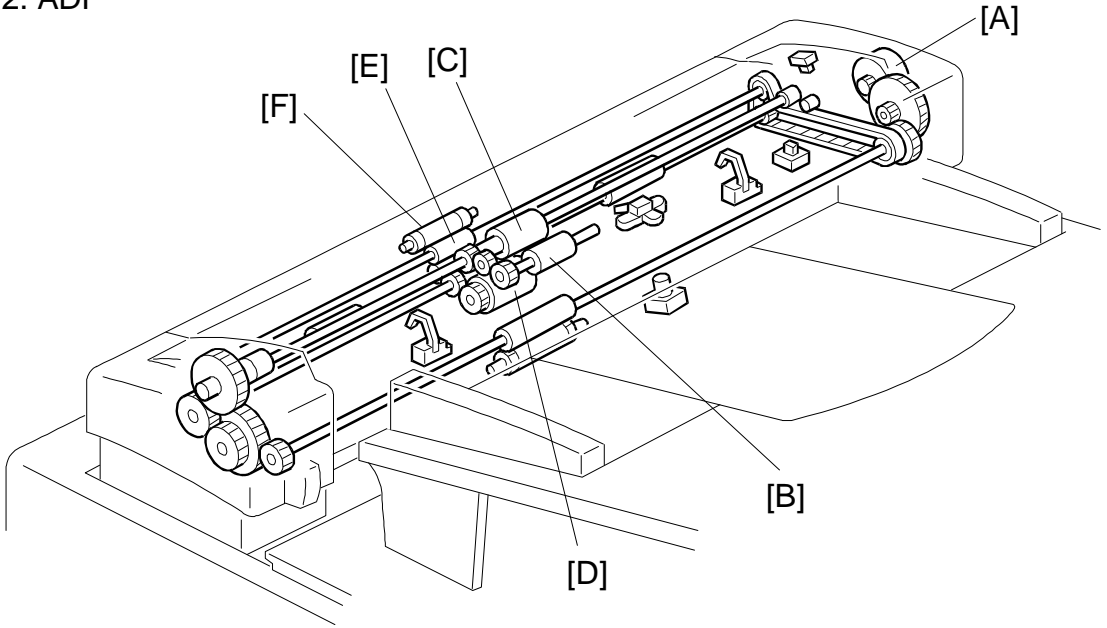

The ADF motor [A] drives the pick-up roller [B], the feed roller [C], the R0 roller [D], the R1 roller [E], and the R2 roller [F].

1.5 PICK-UP AND FEED (ADF)

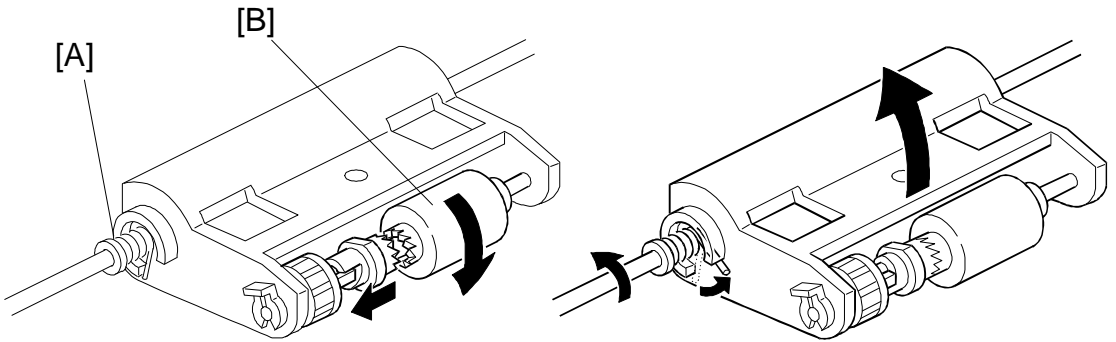

When the ADF motor starts, the mechanical clutch [A] moves the pick-up roller [B] down to the document. Then, the machine feeds the top page of the document. After the last page is scanned, the ADF motor reverses briefly to move the pick-up roller back to the standby position.

1.6 Separation Mechanism (ADF)

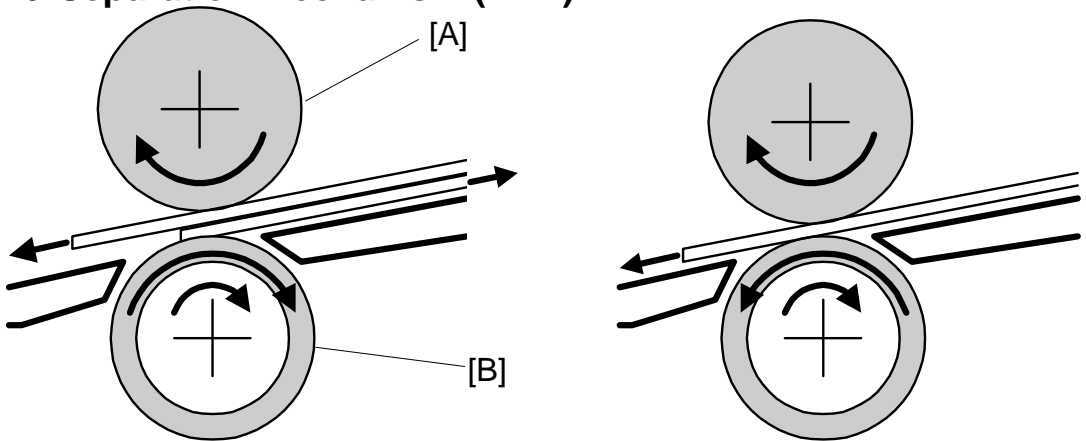

The feed roller [A] and the separation roller [B] prevent more than one sheet of paper from feeding into the scanner at once.

When the feed roller feeds a sheet of paper, both the feed and the separation rollers rotate in the feed-in direction. However, if two or more sheets are between these rollers, the separation roller rotates in the feed-out direction to prevent the lower sheet from being fed into the scanner.

1.7 ERROR CONDITIONS

1. Book Scanner

The main cpu detects an error (Error Code E-13 is displayed) if one of the following conditions occurs.

Condition	Description	Error Code
Incorrect home position sensor condition	The scanner home position sensor did not turn on after the motor moved for more than 7 seconds back to the home position after scanning.	E-13
	The scanner could not leave the home position within 4 seconds of power on. Otherwise, when the scanner could not return to the home position within 2 seconds of leaving.	

2. ADF

"Paper feed jam" is displayed if one of the following conditions occurs.

Jam Condition	Description
Non-feed	The scan line sensor does not switch on within 5 seconds of the ADF motor starting.
Misfeed 1	The scan line sensor does not turn off after turning on even when the trial print is made (when the printing pressure sensor is actuated).
Misfeed 2	When the final page of the document has been fed out of the scanner, or when a jammed document has been removed, the ADF motor reverses. The message is displayed if the document sensor stays on at this time.

2. OPTICS/IMAGE PROCESSING

2.1 OVERVIEW

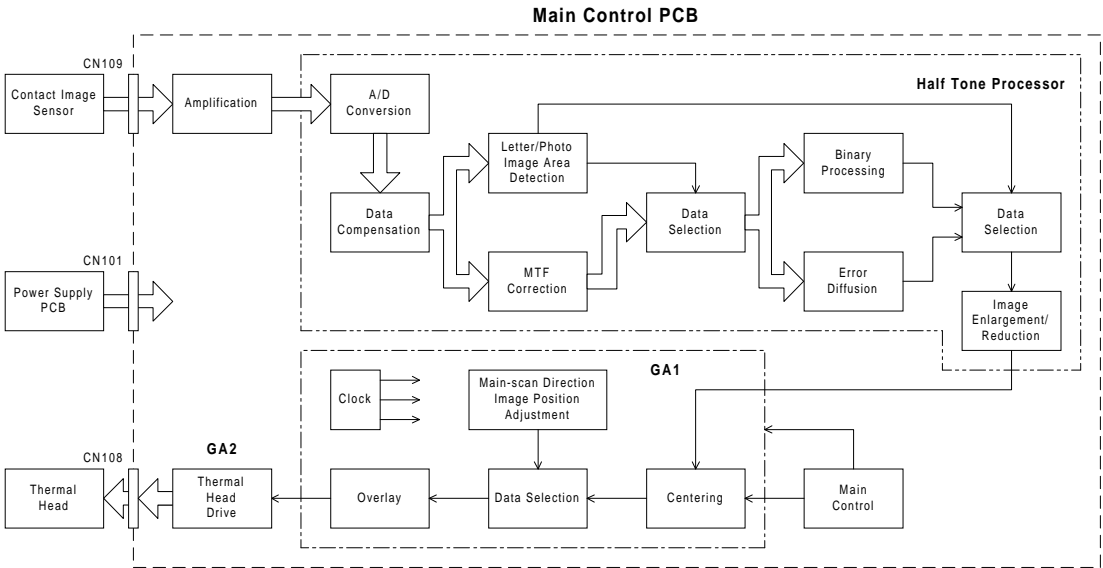

Detailed Descriptions

This model uses a contact image sensor instead of a CCD. This removes the necessity of the complicated adjustments needed for a CCD scanner.

There are 3 main chips on the main control board as shown. This model uses a new type of halftone processing chip. The new halftone processor enables the use of Letter/Photo mode in addition to Letter and Photo modes as the Type of Original selection. In Letter/Photo and Photo modes, error diffusion processing is used. This produces better copy quality halftone images.

The new halftone processor also includes the A/D conversion function, not only the image processing functions. The thermal head drive function is built into a chip (GA2) on the main control board. Therefore, this model does not have a A/D conversion board and thermal head board.

2.2 A/D CONVERSION PROCESSING

The analog signal from the contact image sensor is converted into a digital signal that represents 64 grayscale steps. This process is just like in the other models, however it is carried out in the halftone processing chip while the other models use a separate A/D conversion board.

Shading Distortion Correction

The image data from one main scan line does not exactly represent the line from the original image, because of the following reasons:

- 1) Loss of brightness towards the ends of the exposure lamp.
- 2) Variations in sensitivity among elements of the contact image sensor
- 3) Distortions of the light path

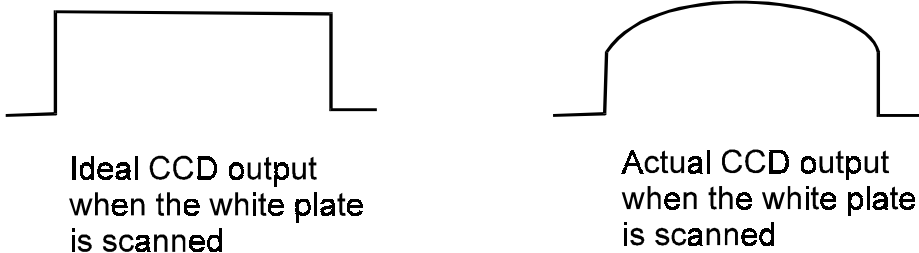

Such distortions in the image data are corrected when they are converted into digital data.

Before scanning the document, the scanner reads the white plate on the back of the original scale. The output of each contact image sensor element is changed to a 6-bit digital value and stored in the shading distortion memory.

To change the analog shading distortion signals to digital data, a scale of 64 steps is made between the whitest level when the white plate is scanned and 50% of the whitest level. Using this scale, the analog signal is changed to 6-bit digital data.

While an original is scanned, the 6-bit shading distortion value for each pixel is sent in series from memory to the D/A converter, synchronizing with the image signal being sent to the A/D converter. The D/A converter changes the distortion value to an electrical current. The current is converted to the voltage to be used as high reference data for A/D conversion. In this way, the high reference voltage for A/D conversion is changed sequentially for each pixel depending on the shading distortion data for that pixel.

Original Background Correction

When an original is scanned, the whitest level of the original background is stored, and that level is used as the white peak level for A/D conversion. The grayscale is made based on the white peak level of the original. As a result, dark background does not appear on the printout.

If the original background correction is disabled, the whitest level when the white plate is scanned is used for the high reference voltage.

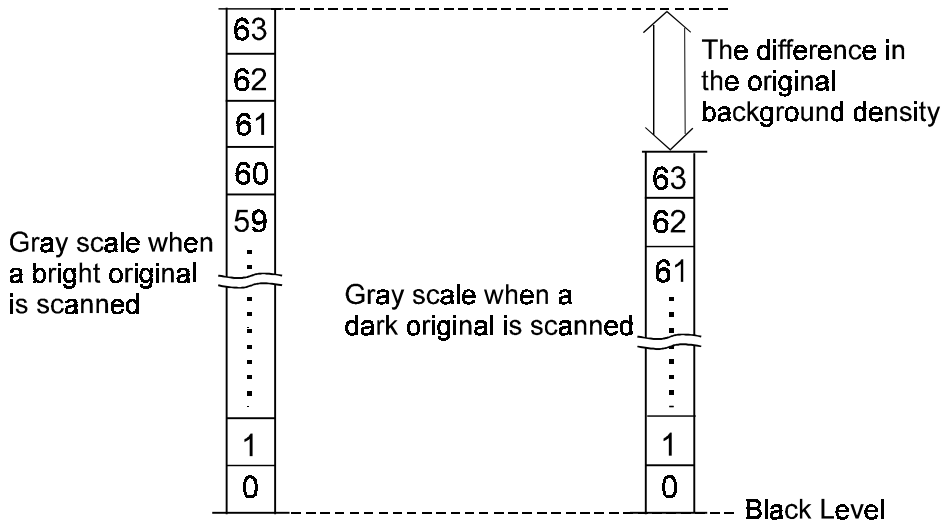

Detailed Descriptions

Peak Hold

The peak hold circuit holds the voltage for the white peak level. Before scanning an original, it holds the white peak voltage from the white plate to make shading distortion data. When the original is scanned, it stores the white peak level of the original for the original background correction.

NOTE: The white peak level is checked 5 mm from the leading edge of the original set on the exposure glass (and from the central 147 mm width). If the original leading edge is not flush with the original scale and the platen cover stays open, insufficient voltage will be input as the white peak level. If insufficient voltage is detected, a fixed voltage is used as the white peak level to avoid a faint image copy.

2.3 BINARY PROCESSING

In the halftone processing chip, the 6-bit digital signal data is generated in the A/D conversion circuit and is sent to the binary processing circuit. At that time the data is inverted to match the binary processing circuit. Therefore, the white peak level becomes 0, and the black level becomes 63.

In the binary processing circuit, the 6-bit data is converted into 1-bit data for black or white pixels. The binary process for the letter mode is different from that for the photo mode and the letter/photo mode as follows:

Letter Mode: MTF (Modulation Transfer Function) Correction

Photo Mode: Error Diffusion Processing

Data Compensation Processing

In this process, the 6-bit data are converted based on a compensation curve (γ curve) which corresponds to selected image settings. For example, if a darker image is selected, a compensation curve which converts each pixel value to a higher number is selected. The output data is also 6-bit.

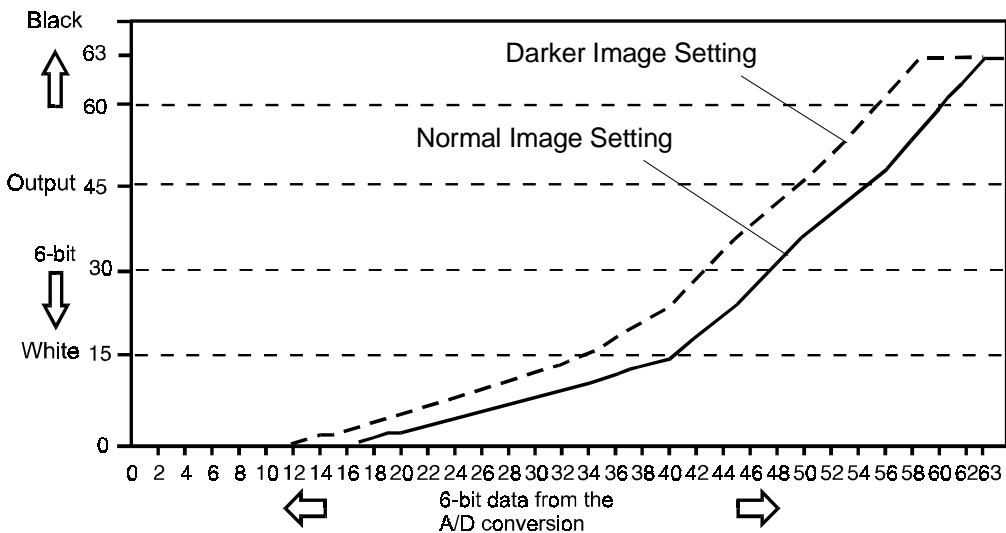
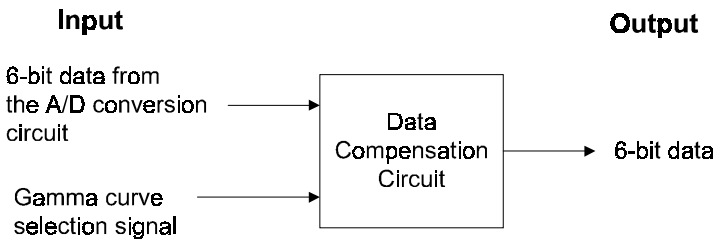

MTF Correction

When the original image is converted to electrical signals by the contact image sensor, the contrast is reduced. This is because neighboring black and white parts of the image influence each other. This symptom is typical when the width and spacing between black and white areas are narrow. MTF correction counters this symptom and emphasizes image detail. The value of a target pixel is modified depending on the value of surrounding pixels. The modified data are compared with a threshold level. This determines if the pixel is to be black or white.

The value [E] of the target pixel [e] is calculated with the following formula:

$$E = e + 2 \left(e - \frac{a+b+c+d+f+g+h+i}{8} \right)$$

a	b	c
d	e	f
g	h	i

After the MTF correction is done, the corrected data are compared with the black or white threshold level. If a pixel value is above the threshold level, it is set to black. If the pixel value is equal or below the threshold level, it is set to white. The threshold level depends on the selected density setting.

Image Density Setting	Threshold Level for Line Mode	Threshold Level for Line Areas in Line/Photo Mode
Lighter	28	35
Normal	35	40
Darker 1	38	42
Darker 2	42	44

Error Diffusion

Error Diffusion is used to reproduce halftone images in Photo mode.

Before a 6-bit image signal is converted into a single-bit signal based on the threshold level, there is a difference between the image signal value and the complete black value (63 for a 6-bit signal) or white value (0). With the Error Diffusion process, the difference is distributed among the surrounding pixels. (The MTF process simply erases these differences.)

When considering Error Diffusion in one dimension only (across the page), the 6-bit data shown in the example below produces white and black data output as shown below. In practice, this one-dimensional Error Diffusion is done in all directions on each pixel (across the page, down the page, etc.).

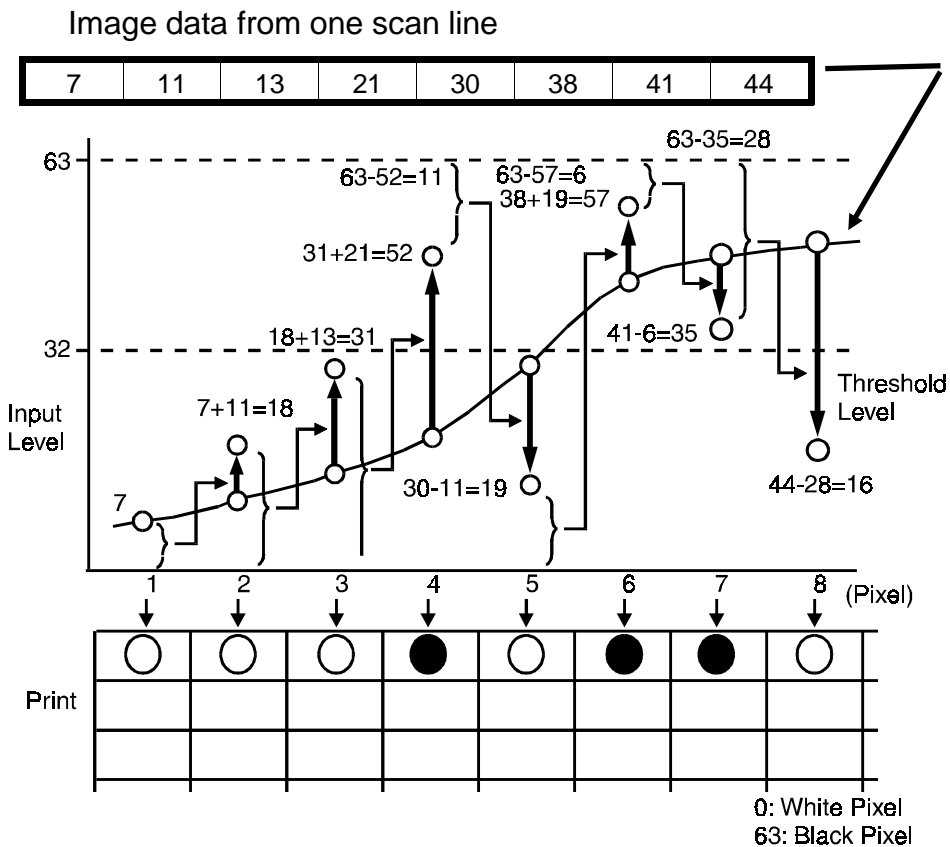

In each dimension, the difference between the pixel value and the nearest extreme (0 or 63) is transferred to the next pixel. The 1st pixel in the row becomes either black or white, whichever is closest. Then, for the 1st pixel above, the difference between 7 and 0 is added to the 2nd pixel. The value of the 2nd pixel, which is now 18, is then added to the 3rd pixel. The 4th pixel becomes 52, which is closer to 63 than 0. In such cases, the difference is subtracted (not added) to get the next pixel value. In this example, the difference is $63-52=11$, and the next pixel value ($30-11$) becomes 19.

Binary Processing in Letter/Photo Mode

In the Letter/Photo mode, the machine checks each pixel of the original to see if the pixel is in a line area or in a photo area. To recognize a line area in a photo original, the CPU does the following calculation on the 6-bit pixel data.

	Main Scan Direction		
	a	b	c
Sub-scan Direction	d	e	f
	g	h	i

$$x = | (c + f + i) - (a + d + g) |$$

$$y = | (g + h + i) - (a + b + c) |$$

If x or y is greater than 10, the machine recognizes that pixel e is in a letter area of the image and uses the MTF process to convert the 6-bit value to 1-bit.

If the calculated number is 10 or less, the pixel is converted to 1-bit using Error Diffusion.

To emphasize characters in a photo original when using Letter/Photo mode, a data compensation curve (γ curve) is used to make a darker image.

Main Scan Magnification

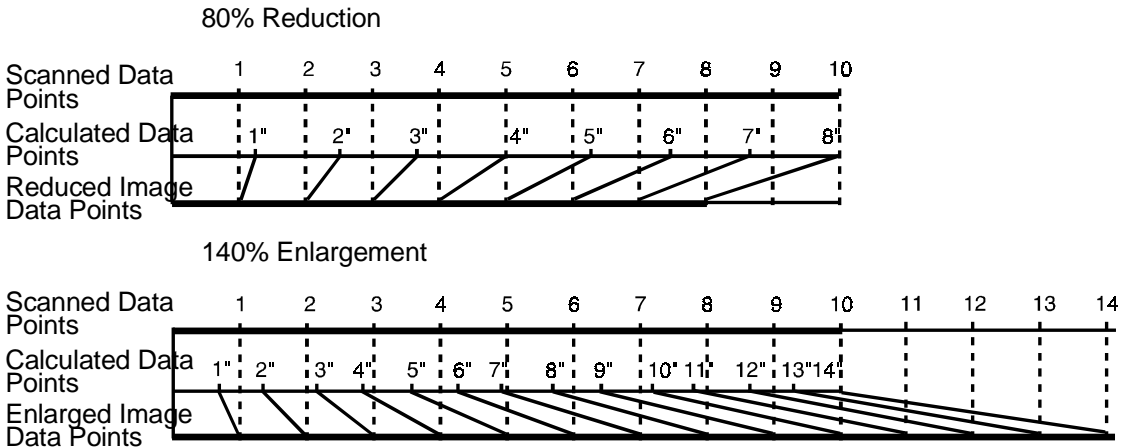

Reduction and enlargement in the sub-scanning direction is done by changing the original transport motor speed. Reduction and enlargement in the main scanning direction is handled by the magnification and image shift processing.

Pixels for scanning and master making are generated at fixed intervals (the contact image sensor and thermal head element intervals). The image is scanned at the contact image sensor element interval. If pixels on the master are made at the same interval (by the thermal head elements) then the master image is the same size as the original.

80 % Reduction

For example, data for 10 pixels in a main scan line are scanned by the contact image sensor. Those data are compressed into data for 8 pixels by the magnification processor. As a result, the image is reduced to 80 %.

140 % Enlargement

Data for 10 pixels of a main scan line are expanded into data for 14 pixels. As a result the image is enlarged with a 140 % magnification ratio.

When actual pixels are divided in accordance with a magnification ratio, the values of the imaginary points that would correspond to new pixels are calculated by the magnification processor. The proper value for each imaginary point is calculated based on the image data of the surrounding pixel values.

Image Position Adjustment in the Main Scan Direction

To adjust the image position of the original across the printout, the image can be shifted ± 1.9 mm in the main scan direction using SP mode No. 31 (platen mode) or No. 37 (ADF mode).

The image shift in the main scan direction is done by changing the relationship between the original scanning start timing and the master making start timing. Data for one main scan line are stored in a line memory. When the data is output from memory, the output timing is changed to shift the image.

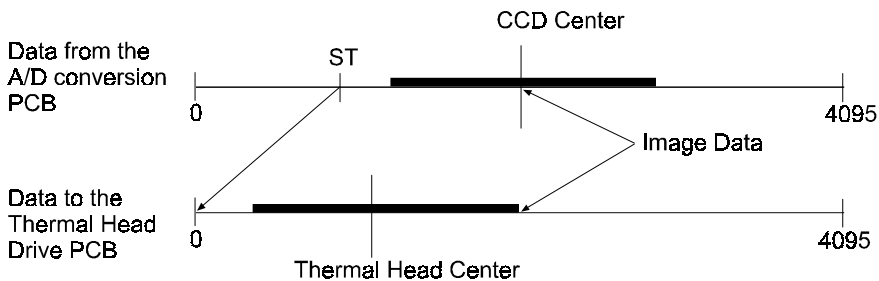

Paste Shadow Erase Mode

Due to the characteristics of the contact image sensor, shadows of a paste-up original tend to appear on copies. To counter this, the paste shadow erase mode can be used by pressing a key on the operation panel.

When this mode is selected, the black or white threshold level is slightly lowered. At the same time, the emphasis in the sub-scan direction in the MTF correction process is weakened to make the shadows inconspicuous.

SECTION 3
INSTALLATION

1. INSTALLATION REQUIREMENTS

The installation location should be carefully chosen because the environmental conditions greatly affect the performance of a machine.

1.1 OPTIMUM ENVIRONMENTAL CONDITIONS:

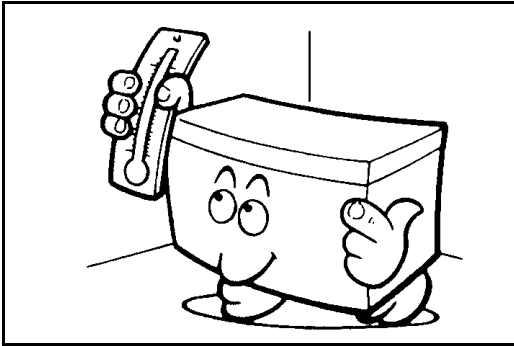

Temperature: 10 to 30°C
(50 to 86°F)

Humidity:
Main frame: 20 to 90% RH
Document feeder (option):
20 to 70% RH

NOTE: If you use the optional document feeder in high humidity conditions, original misfeeds may occur. In such cases, use the platen mode.

On a strong and level base.
The machine must be level within 5 mm (13/64") both front to rear and left to right.

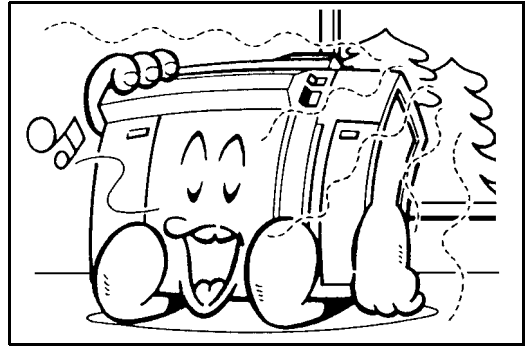

Wide, well-ventilated room.
Minimum ventilation:
air turnover 3 times / hour

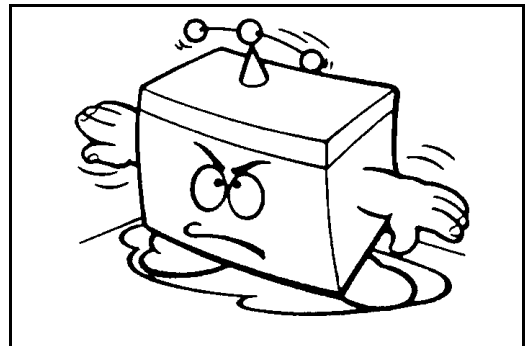

1.2 ENVIRONMENTS TO AVOID:

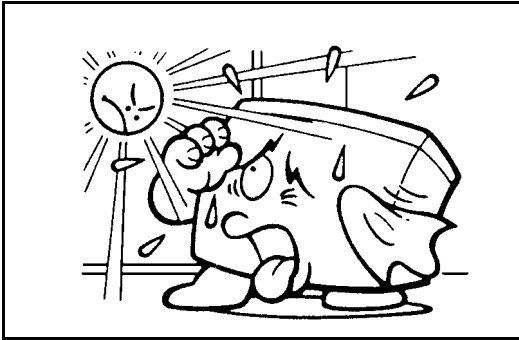

Location exposed to direct sun-light or strong light (more than 1,500 lux).

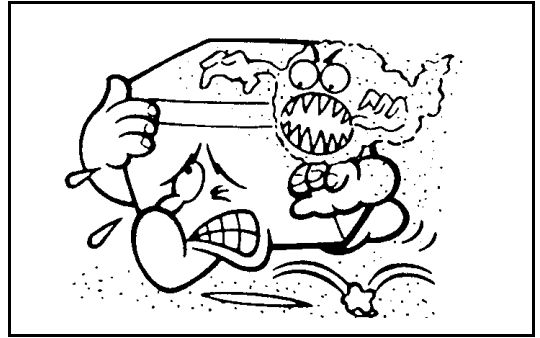

Dusty areas.

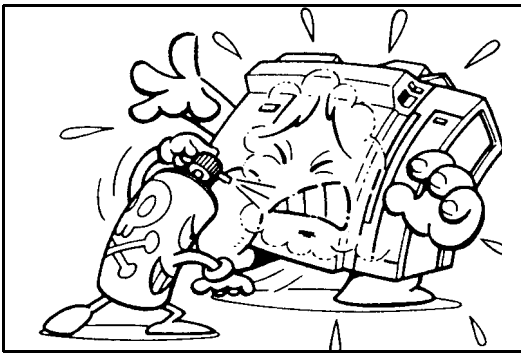

Areas with corrosive gases.

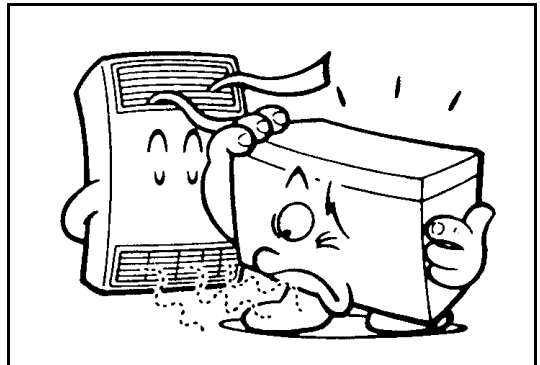

Locations directly exposed to cool air from an air conditioner or to reflected heat from a space heater. (Sudden temperature changes from low to high or vice versa may cause condensation within the machine.)

1.3 GROUND:

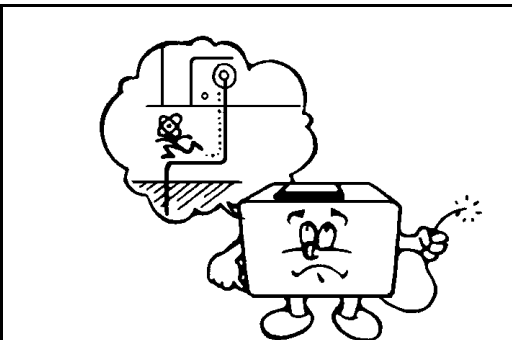

Be sure to ground the machine. Never connect the ground line to gas pipes.

1.4 POWER CONNECTION:

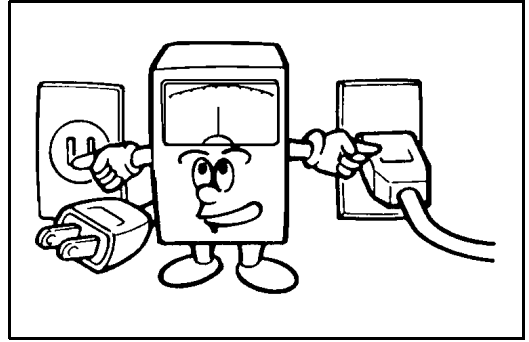
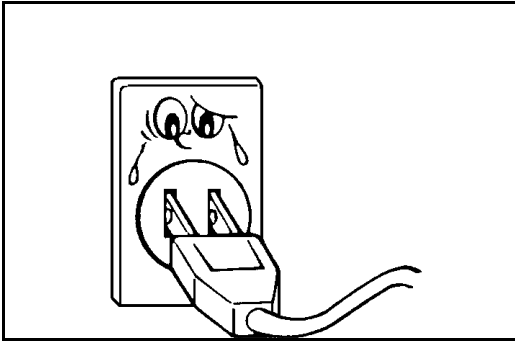

Securely connect the power cord to a power source.

- a) 110V, 60 Hz: More than 6.0 A
- b) 120V, 60Hz: More than 5.5 A
- c) 220V 240V, 50Hz: More than 2.7 A

Voltage must not fluctuate more than 10%.

Installation

Make sure the plug is firmly inserted in the outlet.

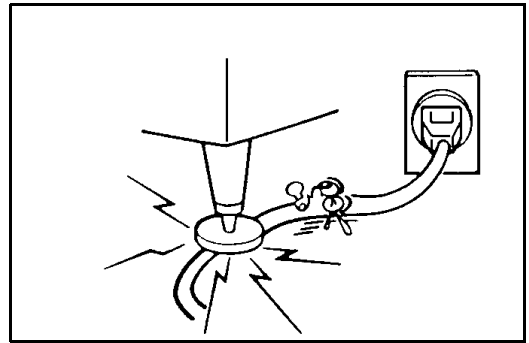
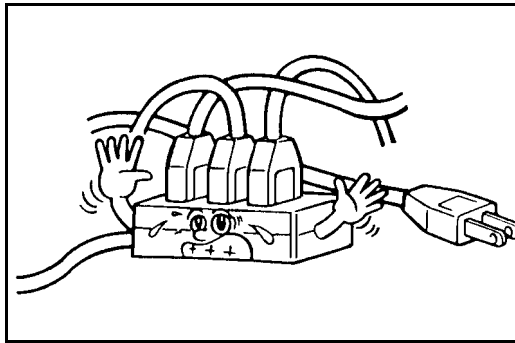

Avoid multiwiring.

Do not pinch the power cord.

1.5 ACCESS TO MACHINE:

Place the machine near a power source, providing clearance as shown below.

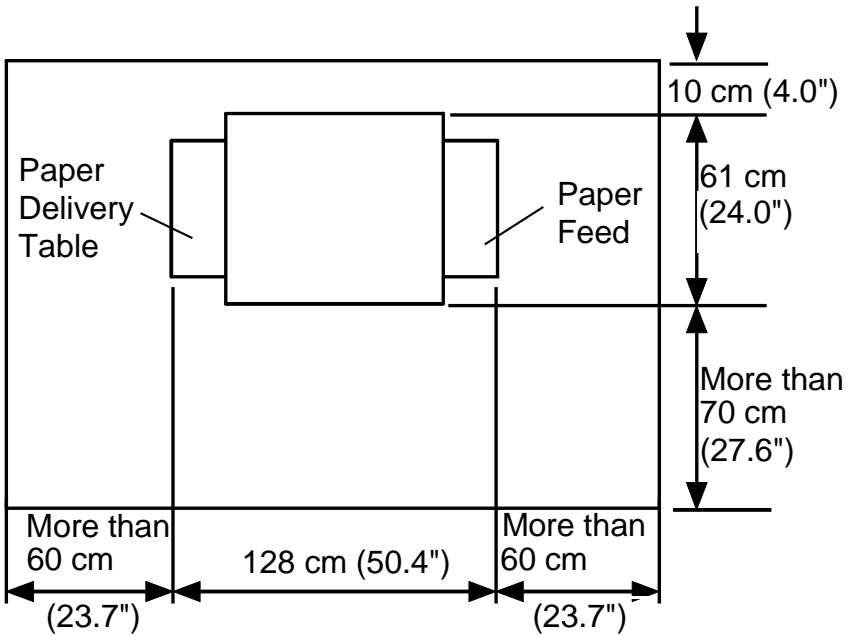

2. INSTALLATION PROCEDURE

2.1 MAIN BODY

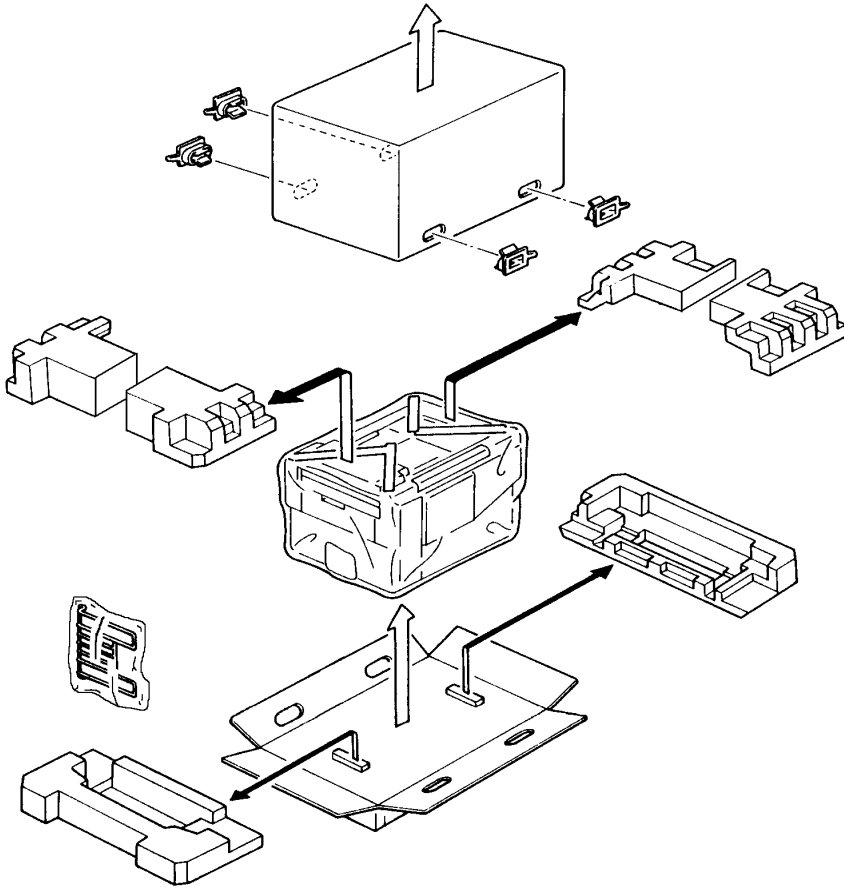

Installation

1. Make sure that you have all the accessories listed below.

- (1) Master Spools2
- (2) Auxiliary End Fence (for Paper Delivery Table).....1
- (3) Operating Instructions (USA and Asia versions only).....1

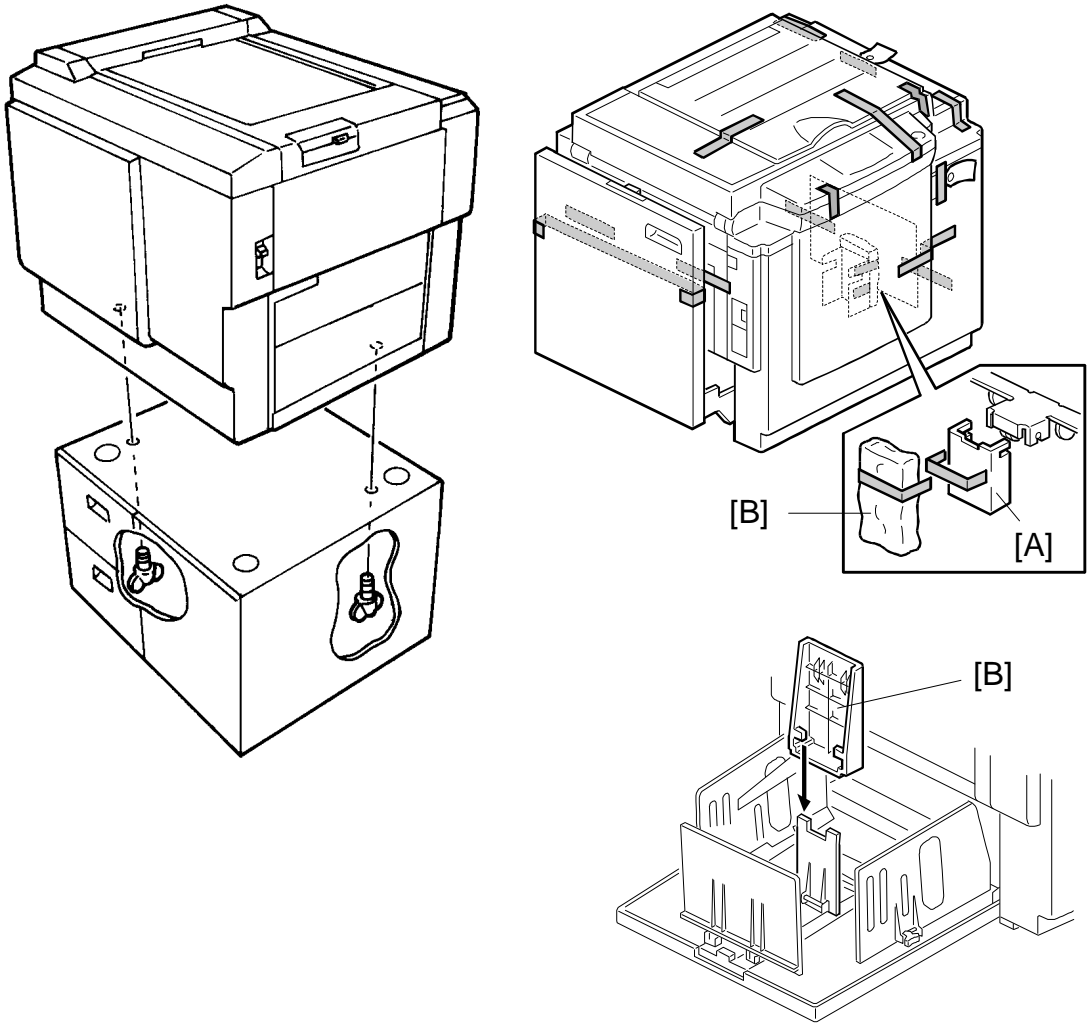

2. Mount the machine on the optional table (2 screws packed with the table).
3. Remove the strips of tape securing the covers and units as shown on the right.
 - a. Open the paper feed tray. Then remove the cushion plate [A] from the paper feed roller section.
 - b. Keep the auxiliary end fence [B] for future use.
 - c. Open the master delivery unit. Then remove the tape securing the paper delivery guide plate.

4. Open the scanner unit, and remove the shipping clamp [A].

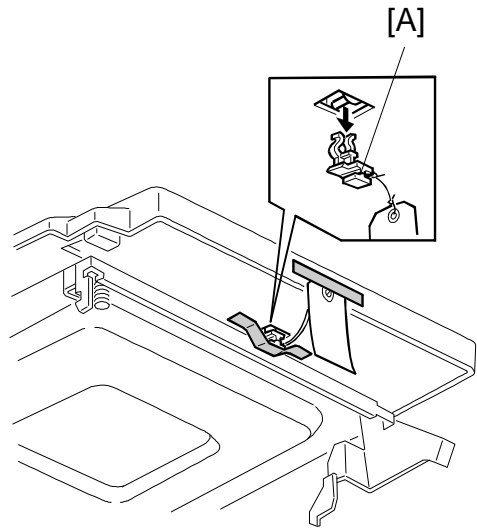

5. Remove the protective sheet [B] from the drum unit.
- Open the front door.
 - Take out the drum unit.
 - Remove the protective sheet from the master clamber.
 - Reinstall the drum unit in the machine.
 - Push down the drum lock lever [C].

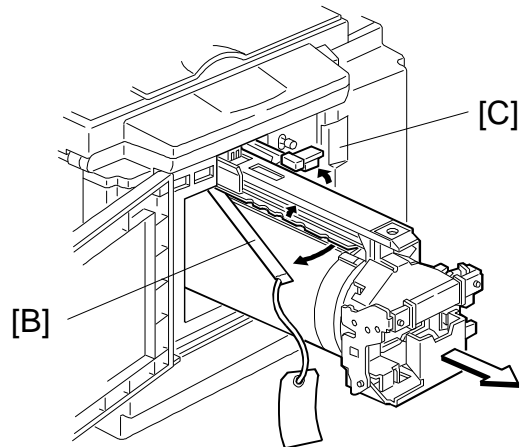

6. Open the scanner unit and plotter unit upper cover, and take the master spools [D] out.

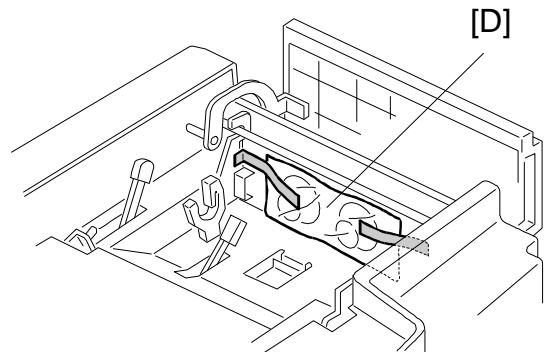

7. Installing the Master Roll
(Type VT-II-M)

- a. Attach a spool to each end of the master roll.
- b. Set the master roll in the machine.
NOTE: The vinyl side faces down.
- c. Return the pressure release lever to the original position.
- d. Plug in the power cord and turn on the main switch.
- e. Press the Master Cut button.
- f. Remove the cut master paper.
NOTE: Check that the master paper is not bent or creased.
- g. Close the upper cover and scanner unit.

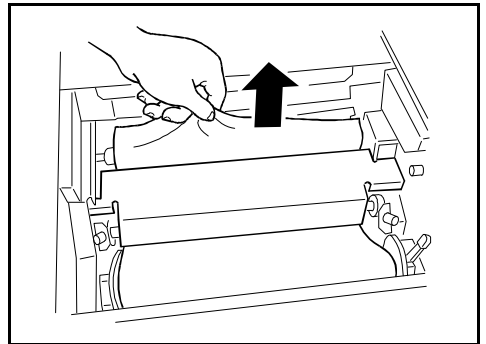
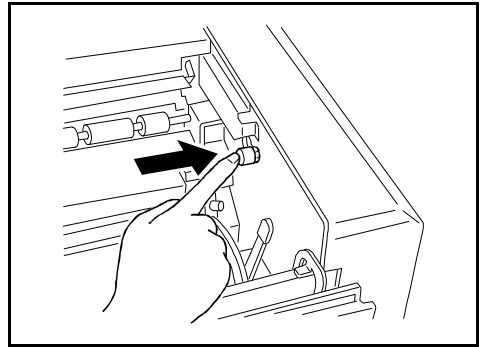
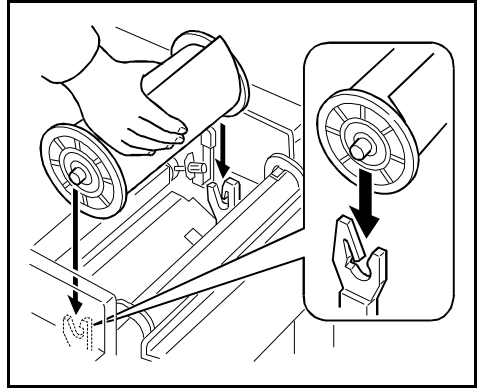

8. Installing the Ink Cartridge

- a. Open the front door and lower the ink holder.
- b. Remove the ink cartridge cap.
- c. Insert the ink cartridge into the ink holder and return the ink holder to the original position.
- d. Close the front door.

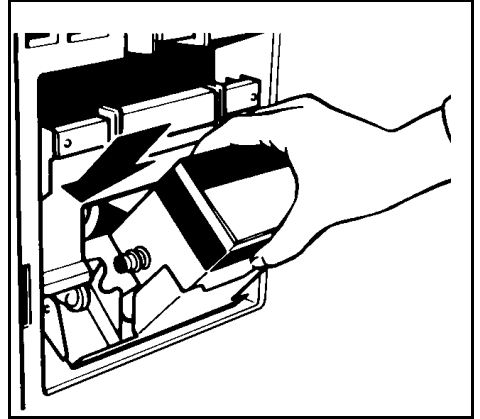

9. Loading Paper on the Paper Feed Table

- a. Open the paper feed table.
- b. Stack the paper neatly on the paper feed table.
- c. Position the paper feed side plates so that they gently contact the paper on both sides.
- d. Position the paper delivery table for the printing paper size, using the scale on the table.
- e. Position the paper delivery side plate for the printing paper size, using the scale on the table.

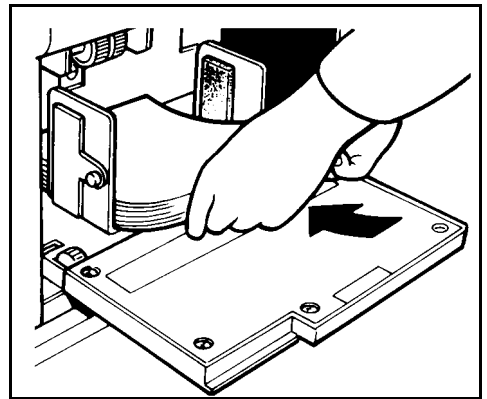

10. Idling

- a. While holding down the "0" key on the operation panel, press the Reset key.
- b. If "LOAD NEW INK CARTRIDGE" is displayed on the operation panel, repeat step 10-a.

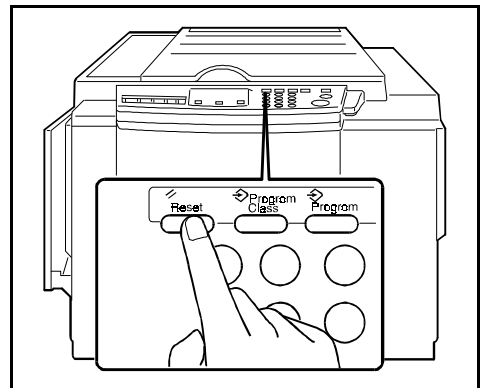

11. Test Printing

- a. Place an original face down and close the platen cover.
- b. Input the desired number of prints with the number keys and press the Start key.

NOTE: With a new machine, "MASTER EJECT JAM" will be displayed because there is no master yet on the drum. Press the Reset key, then press the Start key again.

- c. After one sheet of paper is delivered, make prints at the lowest print speed (1) until the print image density stabilizes. Use a test chart to check for changes in the image density.
- d. Check the copy quality after the image is stabilized.

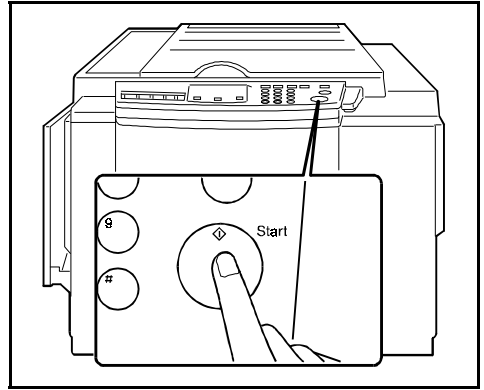

12. This procedure is for the NRG version model only.

Attach the brand decal [A] as shown below.

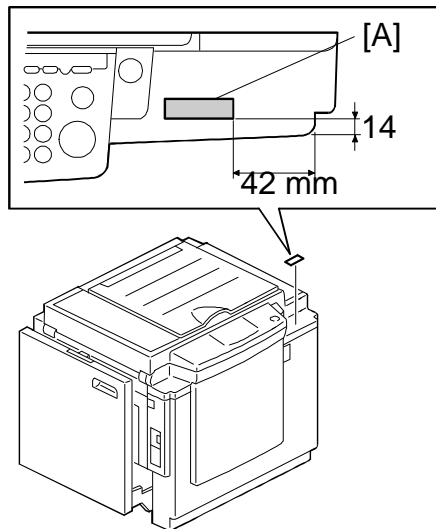

2.2 ADF (Option)

Accessory Check

Make sure that you have all the accessories listed below:

ADF Unit	1
Upper Front Cover	1
Upper Rear Cover	1
Lower Front Cover	1
Lower Rear Cover	1
Connector Cover	1
ADF Roller Assembly	1
Original Table	1
Platen Cover Stopper	1
M3 x 8 Screws (to install the lower front/rear covers)	4
M3 x 6 Sunken Screws (to install the upper front/rear covers)	2

Installation Procedure

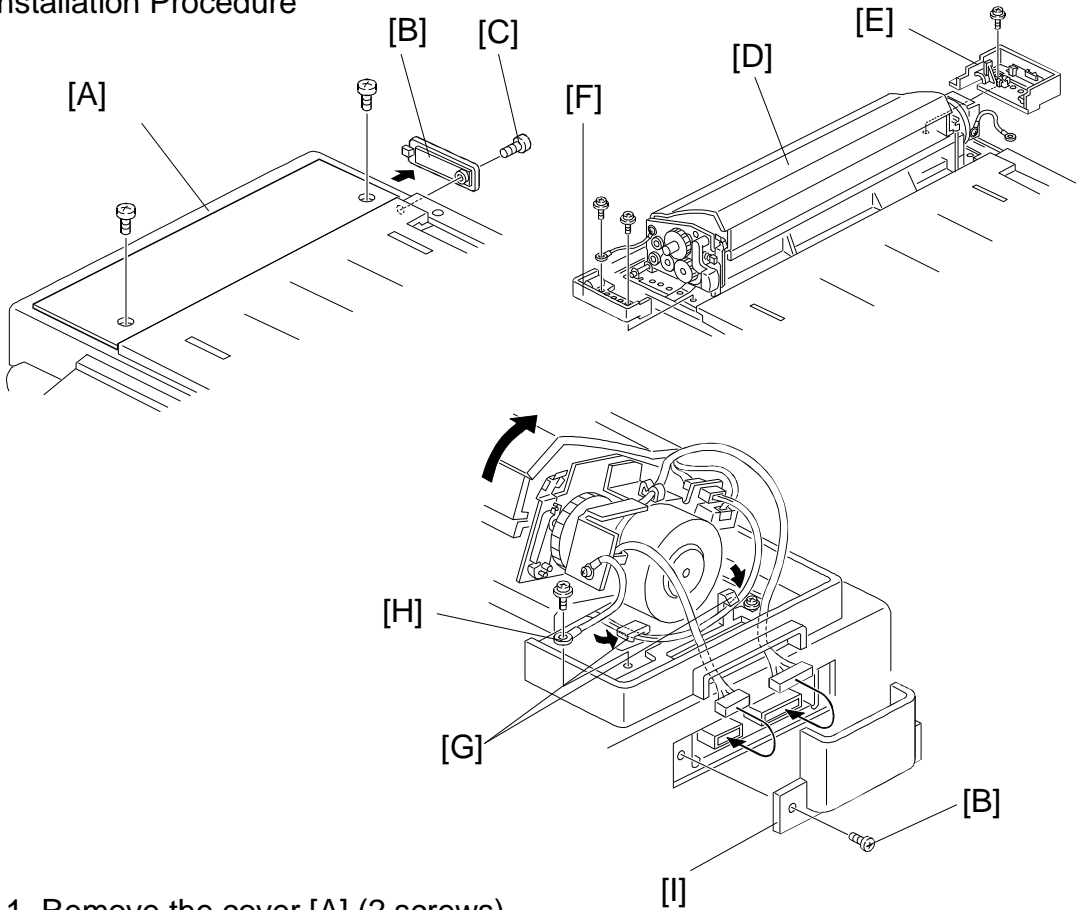

1. Remove the cover [A] (2 screws).
2. Remove the small cover [B] (1 screw). Retain the screw [C] for step 9.
3. Mount the ADF unit [D].
4. Secure the non-operation side of the ADF unit with the ADF Lower Rear Cover [E] (1 screw).
5. Secure the operation side of the ADF unit with the ADF Lower Front Cover [F] (2 screws). Secure the grounding wire with one of the two screws.
6. Secure the harness with the two clamps [G].
7. Secure the grounding wire [H] (1 screw).
8. Pass the two harnesses through the cutout in the ADF Lower Rear Cover, then connect the harnesses to the main body.
9. Install the Connector Cover [I] with the screw [B] removed in step 2.



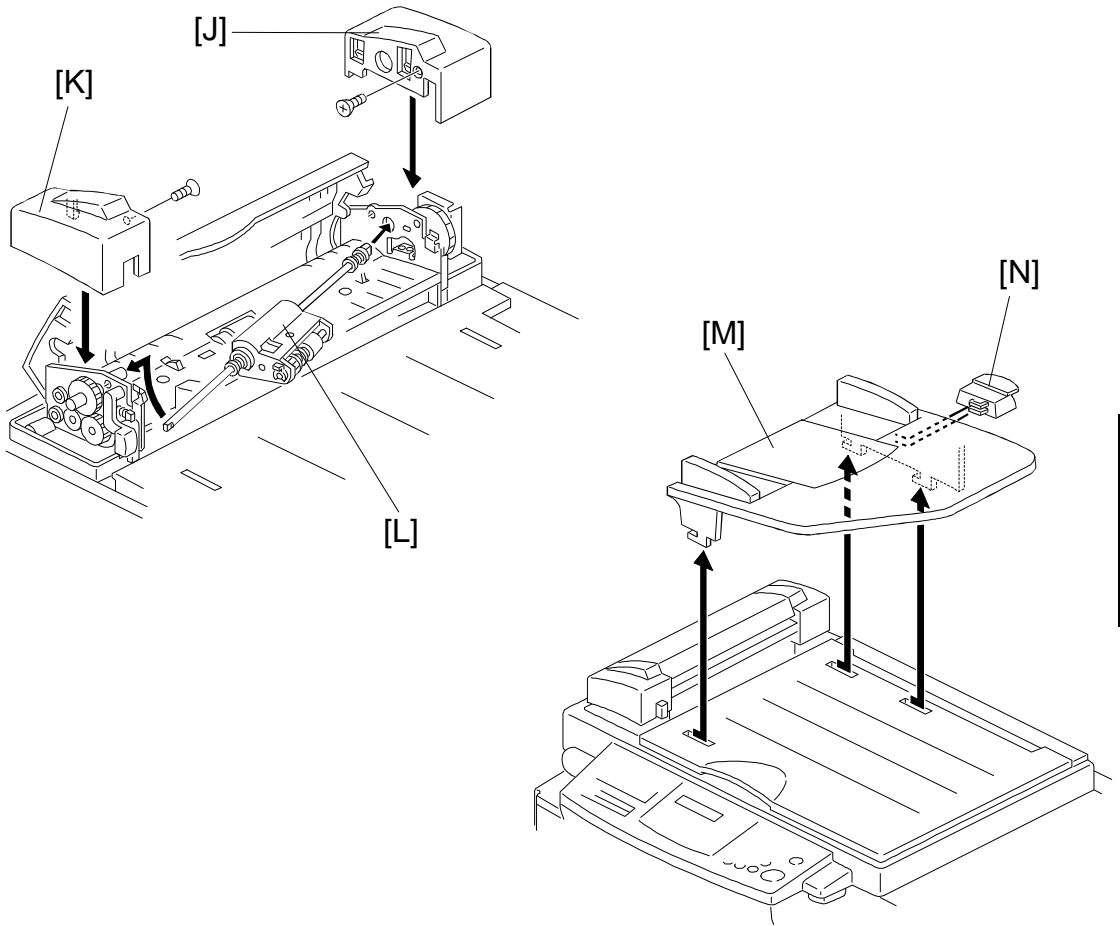

10. Install the ADF Upper Rear Cover [J] (1 sunken screw and 1 hook).
11. Install the ADF Upper Front Cover [K] (1 sunken screw and 2 hooks).
12. Install the ADF Roller Assembly [L].
13. Install the Original Table [M], then install the Platen Cover Stopper [N] on it.

NOTE: To enable the use of the ADF function, you must change the SP mode setting. Access the SP mode and set SP No. 2 to "1". For details, refer to "SERVICE PROGRAM TABLE."

3. TAPE MARKER INSTALLATION

3.1 ACCESSORY CHECK

Check the quantity and condition of the accessories in the box against the following list:

1. Knob Screw
(For models #C210, C217, C218, C219, C222, C223,
and C225 only) 2
2. Screw M4 x 25
(For models # C211, C212, C213, C214, C216, C224,
and C226 only) 2
3. Hexagon Nut M4
(For models # C211, C212, C213, C214, C216, C224,
and C226 only) 2
4. Auxiliary Bracket (For model # C226 only) 1
5. Screw M4 x 8 (For model # C226 only) 2
6. Lock Washer (For model # C226 only) 1
7. Lock Washer 1
8. Tape 1

3.2 C211, C212, C213, C214, C216, and C224

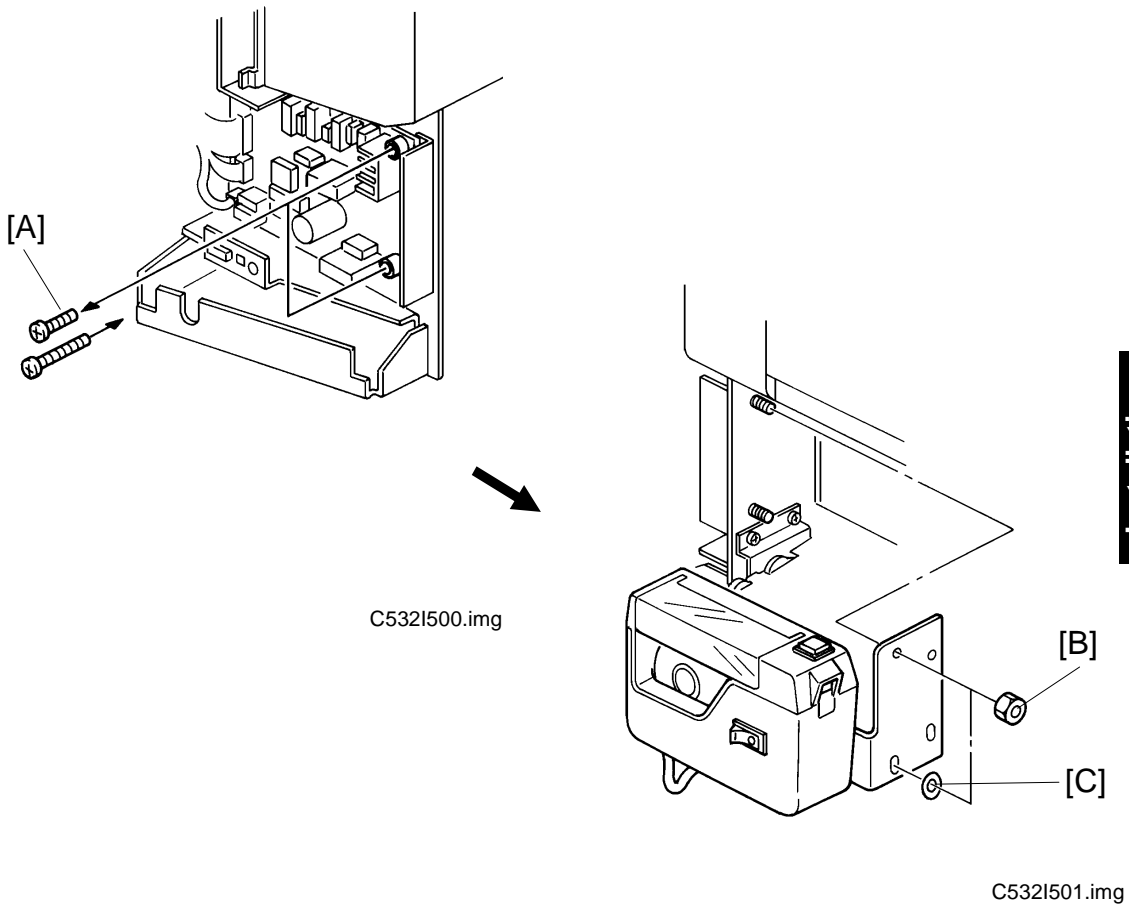

Main Body:

1. Turn off the main switch and unplug the power cord.
2. Remove the rear cover (6 screws).
3. Replace two screws [A], to secure the AC drive PCB with M4 x 25 screws (accessory).
4. Reinstall the rear cover.

Tape Marker:

5. Install the tape marker on the main body in the two inner holes of the tape marker bracket. Then, tighten the two hexagon nuts [B] (accessory).

NOTE: Install the lock washer [C] (accessory) with the lower of the two nuts.

3.3 C226

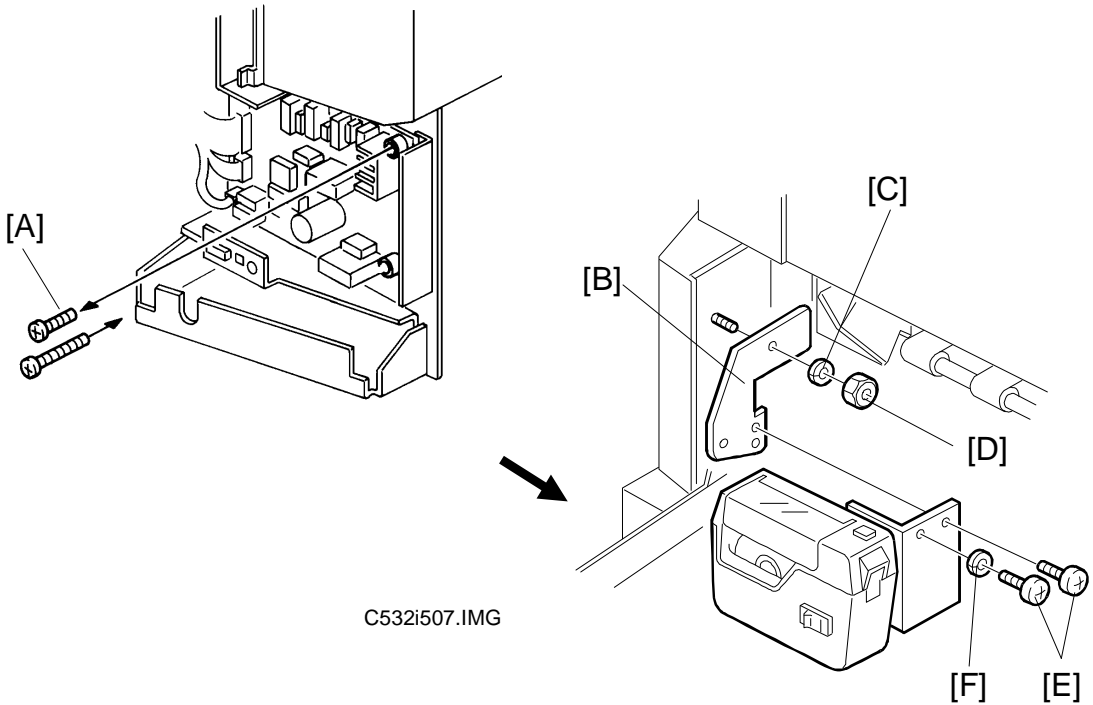

C532i507.IMG

C532i506.wmf

Main Body:

1. Turn off the main switch and unplug the power cord.
2. Remove the rear cover (6 screws).
3. Replace the screw [A], to secure the AC drive PCB with M4 x 25 screws (accessory).
4. Reinstall the rear cover.
5. Install the auxiliary bracket [B] on the main body with the hexagon nut [D] (accessory) as shown.

NOTE: Install the lock washer [C] (accessory) with the nut.

Tape Marker:

6. Install the tape marker on the auxiliary bracket with two M4 x 8 screws [E] (accessory).

NOTE: Install the lock washer [F] (accessory) with one of the two screws.

3.4 C210, C218, C219, C222, and C223

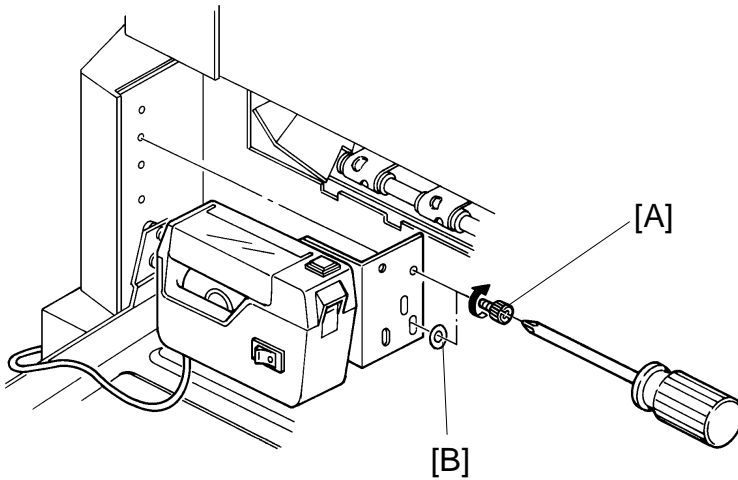

C532I502.img

1. Turn off the main switch and unplug the power cord.

2. Install the tape marker on the main body with two knob screws [A] (accessory) in the two outside holes of the tape marker bracket.

NOTE: 1) Tighten the knob screws with a screwdriver to prevent them from coming loose.

2) Install the lock washer [B] (accessory) with the lower of the two knob screws.

– When The New Paper Delivery Table is Installed –

Use the two holes of the tape marker bracket [C] as shown below.

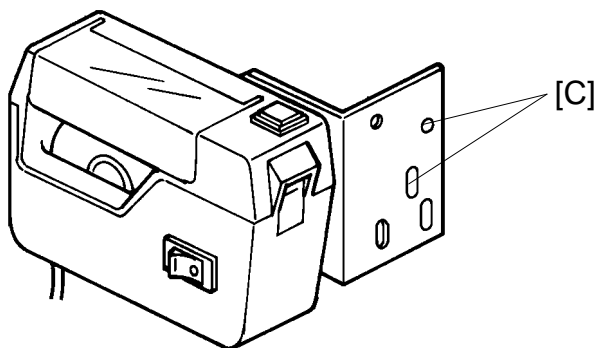

A532I504.img

3.5 C217 and C225

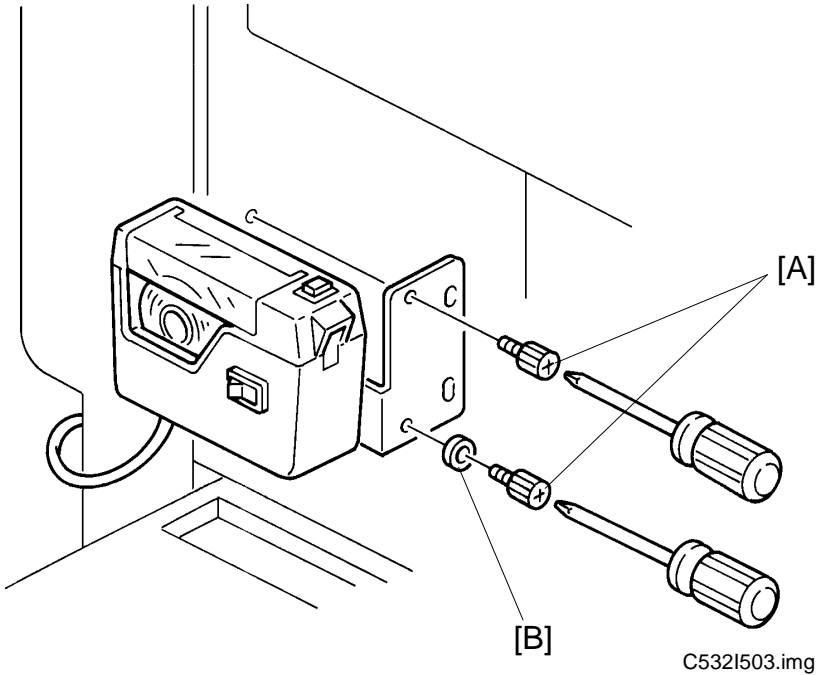

1. Turn off the main switch and unplug the power cord.

2. Install the tape marker on the main body with two knob screws [A] (accessory) in the two inside holes of the tape marker bracket.

NOTE: 1) Tighten the knob screws with a screwdriver to prevent them from coming loose.

2) Install the lock washer [B] (accessory) with the lower of the two knob screws.

SECTION 4

SERVICE TABLES

1. MAINTENANCE TABLES

1.1 LUBRICATION POINTS

Lubricate after removing adhering ink and paper dust.

Lubrication Point	Interval	Type
Bearings for drum drive shaft	yearly	Oil
Bearing for each cam shaft	yearly	Oil
Bearing for main motor shaft	yearly	Oil
Bearing for speed reduction shaft	yearly	Oil
Gears on the drum drive shaft	yearly	Grease
Gears for each cam	yearly	Grease
Paper feed sector gear	yearly	Grease
Second feed sector gear	yearly	Grease
Edge of each cam	yearly	Grease
Master pressure plate groove	yearly	Grease

Type of Oil and Grease

Oil: Motor Oil (SAE No.20)

Grease: Shell Albania No.2

1.2 USER'S MAINTENANCE

Please advise the customer to clean each item at suitable intervals.

Cleaning Point	Interval	Cleaner
Original platen cover	at any time	Cloth and water
Exposure glass	at any time	Cloth and glass cleaner
Paper feed rollers	at any time	Cloth, and soap and water (or ethyl alcohol)
Press roller	at any time	Cloth, and soap and water (or ethyl alcohol)

1.3 TABLE OF PERIODIC INSPECTION (every 6 months)

Item/Location	Step	Inspection Standard
Original platen cover	cleaning	Wipe off the stain with soft cloth dampened with ethyl alcohol.
Exposure glass	cleaning	Wipe with dry cloth.
Mirror/Sub mirror	cleaning	Use blower brush.
Thermal head	cleaning and image check	Wipe off the stain on the thermal head using thermal head cleaning kit. Check the print image. White line must not exist.
Platen roller	cleaning	Wipe off the paper powder with cloth dampened with water.
Sensors	inspection and cleaning	Check the performance of all the sensors. Remove the stains from sensors with dry cloth.
Press roller	cleaning	Wipe off the ink and paper powder with cloth dampened with ethyl alcohol.
Drum surface	cleaning	Wipe off the ink which is forced out from trail edge of a master and paper powder using cloth dampened with ethyl alcohol.
Master feed and delivery	inspection	Master should be properly fed and clamped, without generation of skew, fold. etc. Master should also be properly delivered without jam.
Paper feed and delivery	inspection	Actually print a few sheets to ensure that paper is smoothly fed and delivered, without generation of skew, folds, wrinkles, etc.
Second paper feed rollers	cleaning	Wipe off the ink and paper powder with cloth dampened with alcohol.
Original transport roller	cleaning	Wipe off paper powder with cloth dampened with water.
ADF		
ADF pick-up, reverse, feed rollers	cleaning	Wipe off paper powder with cloth dampened with water.
ADF R1, R2, R3 rollers	cleaning	Wipe off paper powder with cloth dampened with water.

1.4 TABLE OF PERIODIC INSPECTION (every 12 months)

Item/Location	Step	Inspection Standard
Original platen cover	cleaning	Wipe off stains with soft cloth dampened with ethyl alcohol.
Exposure glass	cleaning	Wipe off the stain with soft cloth dampened with ethyl alcohol.
Fluorescent lamp	cleaning	Wipe with dry cloth.
Mirror/Sub mirror	cleaning	Use blower brush.
Thermal head	cleaning and inspection	Wipe off stains on thermal head using thermal head cleaning kit. Check the print image. White line must not exist.
Platen roller	cleaning	Wipe off paper powder with cloth dampened with water.
Paper feed roller	cleaning	Wipe off paper powder with cloth dampened with water and wipe off ink with cloth dampened with ethyl alcohol.
Separation roller	cleaning	Wipe off paper powder with cloth dampened with water and wipe off ink with cloth dampened with ethyl alcohol.
Sensors	inspection and cleaning	Check the performance of all the sensors. Wipe off stains on the sensor with dry cloth.
Master delivery rollers	cleaning	Wipe off the built up ink and paper powder on the master delivery rollers using cloth dampened with ethyl alcohol.
Master delivery belts	cleaning	Wipe off the built up ink and paper powder on the master delivery belts using cloth dampened with ethyl alcohol.
Second paper feed rollers	cleaning	Wipe off the built up ink and paper powder on the second feed rollers using cloth dampened with ethyl alcohol.
Press roller	cleaning	Wipe off the built up ink and paper powder on the press roller using cloth dampened with ethyl alcohol.
Drum surface	cleaning	Wipe off the ink, which is forced out from trail edge of a master, and paper powder using cloth dampened with ethyl alcohol.
Master feed and delivery	inspection	Master should be properly fed and clamped without generation of skew, fold, etc. Master should also be properly delivered without jam.
Paper feed and delivery	inspection	Actually print a few sheets to ensure that paper is smoothly fed and delivered without generation of skew, folds, wrinkles, etc.
Original transport roller	cleaning	Wipe off paper powder with cloth dampened with water.
Lubrication points	Lubrication	Lubricate the lubrication points by following lubrication points list.

Item/Location	Step	Inspection Standard
ADF		
ADF pick-up, reverse, feed rollers	cleaning	Wipe off paper powder with cloth dampened with water.
ADF R1, R2, R3 rollers	cleaning	Wipe off paper powder with cloth dampened with water.

2. EXPECTED LIFE OF PARTS

NOTE: Main parts have the following expected life.

Target Copy Volume Range: Avg. 50,000 prints/month.
 (Max. 100,000 ~ Min. 20,000 prints/month)
 Avg. 500 masters/month

Section	Part Description	Expected Life
Master Feed Unit	Thermal head	30,000 masters
	Cutter	30,000 masters
	Platen roller	30,000 masters
Drum Unit	Drum screen	2 years or 1,200,000 prints
Paper Feed Unit	Paper feed rubber side plate	1,200,000 prints
	Paper feed roller	6 months or 300,000 prints
	Upper separation roller	1 year or 600,000 prints
	Separation plate	1 year or 600,000 prints
	Lower separation roller	2,000,000 prints
	Feed roller brake	1,000,000 prints
Printing Unit	Pressure roller	2 years or 1,200,000 prints
Delivery Unit	Vacuum belts	2 years or 1,200,000 prints
ADF Unit	Pick-up roller	30,000 sheets
	Reverse roller	30,000 sheets
	Feed roller	30,000 sheets

Service Tables

3. SPECIAL TOOLS

Description	Parts Number	Remarks
Drum gauge	C2009001	
Image shifting gauge	C2009002	

4. TABLE OF SERVICE CALL INDICATIONS

Indication	Trouble	Possible cause
E 01	Malfunction in the cutter section: The cutter does not reach both right and left cutter position switches within 2 seconds.	1) Drive wire cut 2) Drive section malfunction 3) No power supply
E 02	Malfunction in the paper table drive section: The lower limit sensor or the paper table height sensor status does not change even though the paper table Up or Down signal is applied.	1) Drive worm gear broken 2) Mounting screw of the worm gear broken 3) No power supply
E 04	The temperature of the thermal head is high: The temperature of the thermal head becomes greater than 54 °C.	1) Defective thermistor 2) Defective thermal head
E 05	Malfunction in the image shifting section: All the encoder output signals are at the "H" level.	1) Encoder connector of the image shifting section is disconnected. 2) Defective encoder
E 06	Mechanical lock: The drum rotation sensor detects that the drum rotation speed is abnormal.	1) Mechanical lock 2) Main motor failure 3) Blown fuse on the AC drive board
E 09	Malfunction of the thermal head.	1) Defective thermal head 2) Defective thermistor 3) Thermal head harness broken
E-10	Malfunction in the thermal head drive section.	1) Defective main control PCB 2) Thermal head drive wire short circuit
E-11	Image shift motor malfunction: The encoder status does not change within 3 seconds after the encoder motor starts rotating.	1) Image shift motor lock 2) Image shift motor harness broken
E-12	Malfunction in the pressure plate drive section: The upper or lower pressure plate sensor remains activated for more than 4 seconds after the pressure plate motor starts turning. The upper or lower pressure plate sensor is not activated within 8 seconds after the pressure plate starts leaving for the other side.	1) Pressure plate motor lock 2) Pressure plate motor harness broken 3) Pressure plate sensor malfunction
E-13	Scanner malfunction: The scanner home position sensor did not turn on after the motor moved for more than 7 seconds back to the home position after scanning. The scanner could not leave the home position within 4 seconds of power on. Otherwise, when the scanner could not return to the home position within 2 seconds of leaving.	1) Mechanical lock of scanner 2) Defective scanner home position sensor

5. DIP SW, LED, VR, AND TP TABLES

5.1 DIP SWITCH TABLE

DIP SW No.	Function	Remarks	Factory Setting
DPS101	Cover Open OFF	Bypasses the cover safety switches, except for the ADF cover switch. To disable the ADF cover switch function, use SP mode no. 146.	OFF

5.2 LED TABLE

LED No.	Function	Remarks
LED101	Main Motor	Lights when the main motor turns on.
LED102	Second Paper Exit Sensor	Lights when paper is detected.
LED103	First Paper Exit Sensor	Lights when paper is detected.
LED104	Master Eject Sensor	Lights when a master is under the master eject sensor.
LED105	Lights when ink is present.	

5.3 VR TABLE

VR No.	Function
VR101	Adjustment for Drum Speed 5 (120 rpm)
VR102	Second Paper Exit Sensor Adjustment
VR103	First Paper Exit Sensor Adjustment
VR104	Master Eject Sensor Adjustment

5.4 TEST PIN TABLE

Test Pin No.	Function
TP101	Drum Rotation Detection Signal Output
TP102	Second Paper Exit Sensor Voltage
TP103	First Paper Exit Sensor Voltage
TP104	Master Eject Sensor Voltage
TP105	Ink Detection Voltage
TP106	Contact Image Sensor Output
TP107	Clock Signal Output
TP108	Line Synchronized Signal Output
TP109	Grounding

6. SERVICE PROGRAM TABLE (I/O CHECK MODE)

6.1 SERVICE PROGRAM MODE OPERATION

The service program (SP) mode is used to check electrical data, change modes, or change adjustment values.

Service Program Mode Access Procedure (For Engineers)

All service program modes can be accessed with the following procedures.

1. Press the following keys on the operation panel in the following order:

Method 1:

- a) **Clear Modes key**
- b) **Clear (C) key**
- c) **Combine 2 Originals key**
- d) **Enter key**

Method 2:

- a) Turn off the power switch
- b) Press the **Start key**, **Stop key**, and **Clear (C) key** simultaneously
- c) Turn on the power

2. The following is displayed on the LCD when the SP mode is accessed.

SP-MODE PROGRAM No. 0

3. Using the **number keys**, enter the desired SP mode number (listed in the service program table), then press the **Enter (#) key**.

NOTE: The SP mode number can be shifted up or down by pressing the **Select Size And Direction ("<" or ">") keys**.

4. Follow the "Change Adjustment Values or Modes" procedure on the next page. To cancel the SP mode, press the **Clear Modes key**. If you entered the SP mode using Method 2, you can cancel the SP mode only by turning the main switch off then on.

Service Program Mode Access Procedure (For Users)

This procedure allows users to access only the service program modes that are marked with an asterisk in the service program table.

1. Press the **SP Mode key** on the operation panel.
2. The following is displayed on the LCD.

SP-MODE PROGRAM No. 0

3. Using the **number keys**, enter the desired SP mode number (listed in the service program table), then press the **Enter (#) key**.
4. Do the following procedure. To cancel the SP mode, press the **Clear Modes key**.

Change Adjustment Values or Modes

1. After entering the desired SP mode number and pressing the **Enter (#) key**, the current value or mode will be displayed on the LCD (at the end of the second line).
2. Enter the desired value or mode using the **number keys** (listed in the service program table).
Use the **Program Class key** to toggle between + and –.
3. Press the **Enter (#) key** to store the desired value or mode.
4. To cancel the SP mode, press the **Clear Modes key**. If you entered the SP mode using Method 2, you can cancel the SP mode only by turning the main switch off then on.

6.2 SERVICE PROGRAM TABLE

*: Accessible by a customer **: Can be registered in CS mode

No.	Display	Function	Settings	Factory Setting	Comments
1	On Line	Enables On Line key operation.	0: No 1: Yes	0	
2	ADF Unit	Enables ADF operation.	0: No 1: Yes	0	
3	Key Counter	Enables key counter operation.	0: No 1: Yes	0	
4	Key Card	Used only in Japan.	0: No 1: Yes	0	
**5	Tape Marker Off	Disables tape marker operation.	0: No (Use the tape marker) 1: Yes	0	
*10.	Min. Print	Limits the minimum print quantity that can be entered.	0 to 9999	0	
*11	Max. Print	Limits the maximum print quantity that can be entered.	0 to 9999	9999	
12-1	Set Display Mode	Enables SP12-2 operation.	0: No 1: Yes	0	
12-2	0: JPN 1: ENG 2: GER 3: FRE 4: ITA 5: SPA	Selects the language used on the display.	0: No 1: Yes	0	<ul style="list-style-type: none"> •Use after setting SP12-1 to 1. •"1" is set at factory.
13	Set Size Mode	Selects the metric size (mm) or inch size on the display.	0: mm 1: Inch	0	For U.S.A. version models, "1" is set at factory.
**20	Buzzer On	Turns the beeper ON.	0: No 1: Yes	0	
*21	Prints/Master Cost	Adjusts the cost ratio of masters to prints for accounting purposes. (When SP4 is set at 1, this function cannot be used.)	0 to 50	0	The set number (0 to 50) is automatically added to the key counter each time a master is used.
*22	Print Program Class	Select which the printing with the One Touch Class mode is carried out from the first or last class.	0: First 1: Last	0	

No.	Display	Function	Settings	Factory Setting	Comments
**29	Pht Bckgrnd Correct	Determines whether the original background correction is done in Photo mode.	0: Correction is not done. 1: Correction is done.	0	
30	Scan Mag. Adjust	Adjusts the sub-scan magnification.	-1.9 to +1.9%	(0)	<ul style="list-style-type: none"> •For the ADF mode, see SP36. •0.1% steps. •Use the Program Class key for "+" or "-".
31	SCN Center Adjust	Adjusts the center position of copies in the platen mode.	-1.9 to +1.9 mm	0	<ul style="list-style-type: none"> •0.1 mm steps. •Use the Program Class key for "+" or "-". •For the ADF mode, see SP37. See Remarks (2).
33	Lead Edge Margin	Adjusts the lead edge margin.	4 to 10 mm	5	
34	Head Energy Adjust (Normal)	Adjusts the thermal head energy for the normal mode.	0 to -99%	0	
35	Economy Head Energy Adjust	Adjusts the thermal head energy for the Economy mode.	0 to -99%	(-8)	
36	ADF Mag. Adjust	Adjusts the ADF sub-scan magnification.	-1.9 to +1.9%	(0)	<ul style="list-style-type: none"> •For the platen mode, see SP30. •0.1% steps. •Use the Program Class key for "+" or "-".

No.	Display	Function	Settings	Factory Setting	Comments
37	ADF Center Adjust	Adjusts the center position of copies in the ADF mode.	-1.9 to +1.9 mm	0	<ul style="list-style-type: none"> • For the platen mode, see SP31. • 0.1% steps. • Use the Program Class key for "+" or "-". • See Remarks (2).
38	ADF Scan Line Adjust	Adjusts the ADF scanning start position.	-4.9 to 4.9 mm	(0)	<ul style="list-style-type: none"> • 0.1 mm steps. • Use the Program Class key for "+" or "-". • See Remarks (1).
*40	Original	Specifies the image mode at power-up.	0: Letter 1: Lt/Photo 2: Photo	0	
*41	Image Density	Specifies the image density at power-up.	0: Light 1: Standard 2: Dark 3: Darker	1	
*42	Print Speed	Specifies the printing speed at power-up.	0: 60 rpm 1: 75 rpm 2: 90 rpm 3: 105 rpm 4: 120 rpm	2	
*43	Auto Cycle Mode	Specifies whether Auto Cycle mode is selected at power-up.	0: No 1: Yes	0	
*44	0: Master Make 1: Print	Specifies whether Master Making or Printing mode is selected of power-up.	0: Master Making 1: Print	0	
*45	Std. Image Position	Specifies the image position at power-up.	1: +15 mm 2: +10 mm 3: +5 mm 4: 0 mm 5: -5 mm 6: -10 mm 7: -15 mm	4	
60	Clear All Memory	Returns all SP modes to the default settings.	0: No 1: Yes	0	The memory is cleared after pressing the Enter (#) key.

No.	Display	Function	Settings	Factory Setting	Comments
61	Clear Memory/ Except 30, 31, 33 ~ 38	Returns all SP modes to the default settings except for SP No. 30, 31, 33 to 38.	0: No 1: Yes	0	The memory is cleared after pressing the Enter (#) key.
70	Original Feed Jam (A)	Displays the total number of original jams.		0	
71	Paper Feed Jam (B)	Displays the total number of paper feed jams.		0	
72	Paper Wrap Jam (E)/(B)(E)	Displays the total number of times that paper has accidentally wrapped around the drum.		0	
73	Paper Delivery Jam (G)	Displays the total number of paper delivery jams.		0	
74	Master Feed Jam (C)	Displays the total number of master feed jams.		0	
75	Master Delivery Jam (F)	Displays the total number of master delivery jams.		0	
76	Clear Jam Counters	Clears all jam counters.	0: No 1: Yes	0	The memory is cleared after pressing the Enter (#) key.
**81	Quality Print No.	Specifies how many trial prints are made after making a master in Quality Start mode.	0 to 3 sheets	1	
82	Skip Feed No.	Selects the feed interval.	1 to 9	2	1: Normal operation 2 to 9: One sheet fed every two to nine drum rotations
**84	Auto Multi Copy	Specifies the initial mode for the Combine 2 Originals mode.	0: Normal 1: Auto (Two identical images are made if the Master Making key is pressed once.)	0	

No.	Display	Function	Settings	Factory Setting	Comments
85	Initial Compression	Specifies whether full master box detection is made at power-up.	0: No 1: Yes	0	
**88	Auto Class Mode	Specifies whether the Auto Class mode is used.	0: No 1: Yes	0	See Remarks (3).
90	Thermal Head Test	Select "1" to carry out the thermal head test.	0: Off 1: On	0	See the Thermal Head Test section.
92	Thermal Paper Mode	Use this mode to test the thermal head.	0: No 1: Yes	0	See Remarks (4).
95	Scanner Free Run	Selects the type of scanner free run.	0: With the lamp off 1: With the lamp on	0	<ul style="list-style-type: none"> • Start with the Start key. Stop with the Stop key. • See Remarks (5).
96	ADF Original Feed	Carries out the ADF original feed check. (The speed can be changed; see Remarks (6).)	Start with the Print Start key. Stop with the Stop key.		See Remarks (6).
98	Economy Count	Displays the total number of masters made in Economy mode.		0	
103	Margin Erase Count	Displays the total number of masters made with the Margin Erase key.		0	
104	On line Count	Displays the total number of masters made in On Line mode.		0	
105	Overlay Count	Displays the total number of masters made in Overlay mode.		0	
106	Enlarge Count	Displays the total number of masters made in Fixed Enlargement mode.		0	
107	Reduction Count	Displays the total number of masters made in Fixed Reduction mode.		0	
111	Total Count	Displays the total number of masters and prints.		0	M: Master count P: Print count
*113	Resettable Count	Used by the customer to display the total number of masters and prints.		0	M: Master count P: Print count

No.	Display	Function	Settings	Factory Setting	Comments
*114	CLR Resettable Count	Clears the resettable total master/print counters.	0: No 1: Yes	0	
115	ADF Mode Count	Displays the total number of sheets fed in the ADF mode.		0	
116	Scanner Mode Count	Displays the total number of originals set in platen mode.		0	
117	Color Drum Count	Displays the total number of prints made using the color drum.		0	
119	CLR All Total Count	Clears the following counters: SP Nos. 111, 115, 116 and 117.	0: No 1: Yes	0	
*120 -1	User Code Mode	Selects user code mode, and displays the total number of prints made in the User Code mode.	0: No 1: Yes	0	See the user code mode section.
-2	Auto Reset Time	Selects the auto reset time.	0: Unlimited 1: 1 min. 2: 2 min. 3: 3 min. 4: 4 min. 5: 5 min.	0	Displays only when "Yes" is selected in SP120-1.
*121	UC Count	Displays the total number of masters and prints made with each user code.		0	Press the # key to shift to another user code.
*122	Clear UC Count	Clears the selected user code counter.	0: No 1: Yes	0	Same as above.
*123	Total UC Count	Displays the total number of masters and prints for up to 20 user codes.		0	
*124	Clear Total UC Count	Clears the total user code counter.	0: No 1: Yes	0	
130	Input Check Mode	Displays the inputs from sensors and switches.			See the input check table.
131	Output Check Mode	Turns on the electrical components.			See the output check table.
132	All Indicators ON	Turns on all the indicators on the operation panel.			Press the # key to light all the indicators.
135	SN: 1st Paper Exit	Displays the 1st paper exit sensor voltage.			Unit: Volts

No.	Display	Function	Settings	Factory Setting	Comments
136	SN: 2nd Paper Exit	Displays the 2nd paper exit sensor voltage.			Unit: Volts
137	SN: Master Eject	Displays the master eject sensor voltage.			Unit: Volts
140	Ink Detection	Specifies whether ink detection is done.	0: No 1: Yes	1	
141	Paper Detection	Specifies whether paper end detection is done.	0: No 1: Yes	1	
146	ADF Cover Detection	This mode disables the ADF Cover Switch.	0: Disabled 1: Enabled	1	This function is valid only when SP2 is set at "1".
147	ADF Set Detection	This mode disables the Platen Cover Sensor detection.	0: Disabled 1: Enabled	1	If "0" is selected, "Set the original" is displayed each time at master making.
150	Control ROM No.	Displays the ROM part number and the ROM manufacturing date.		P/No.	YYYY/MM/DD
151	Machine No.	Displays the machine serial number and the installation date.		0	Input the serial number and the installation date.
152	Service Tel. No.	Input the service representative's telephone number, which is displayed with the service call code.		0	<ul style="list-style-type: none"> •Use the number keys to input the telephone number at installation. •Press the Program Class key if you wish to add a space between the digits.
153	Last Service Code	Displays the last service call.		0	
*160	Side Ers.	Adjusts the default side edge margin width in the Margin Erase mode.	2 to 20 mm or 0.1 to 0.8 inch	5 mm	Use the Program key to input the number after the decimal point.
*161	Center Ers.	Adjusts the default center margin width in the Margin Erase mode.	4 to 60 mm or 0.2 to 2.3 inch	10 mm	Use the Program key to input the number after the decimal point.

No.	Display	Function	Settings	Factory Setting	Comments
*162	Horizontal Ers.	Adjusts the default horizontal edge (top and bottom) margin in the Margin Erase mode.	2 to 20 mm or 0.1 to 0.8 inch	5 mm	Use the Program key to input the number after the decimal point.
*170	ERS. **1	Enter the original size (in "mm") that you want to use with the Margin Erase mode.	(100 to 258) x (100 to 364) mm or (4.0 to 10.0) x (4.0 to 14.3) inch	0 x 0	<ul style="list-style-type: none"> •The original size entered is displayed by pressing the Select Size And Direction ("$<$" or "$>$") keys when in the Margin Erase mode. •Use the Program key to input the number after the decimal point.
*171	ERS. **2	Enter the original size (in "mm") that you want to use with the Margin Erase mode.	(100 to 258) x (100 to 364) mm or (4.0 to 10.0) x (4.0 to 14.3) inch	0 x 0	Same as above.
*172	ERS. **3	Enter the original size (in "mm") that you want to use with the Margin Erase mode.	(100 to 258) x (100 to 364) mm or (4.0 to 10.0) x (4.0 to 14.3) inch	0 x 0	Same as above

Remarks

1) SP Mode No. 38 – ADF Scan Line Adjust

The printing position moves as shown below.

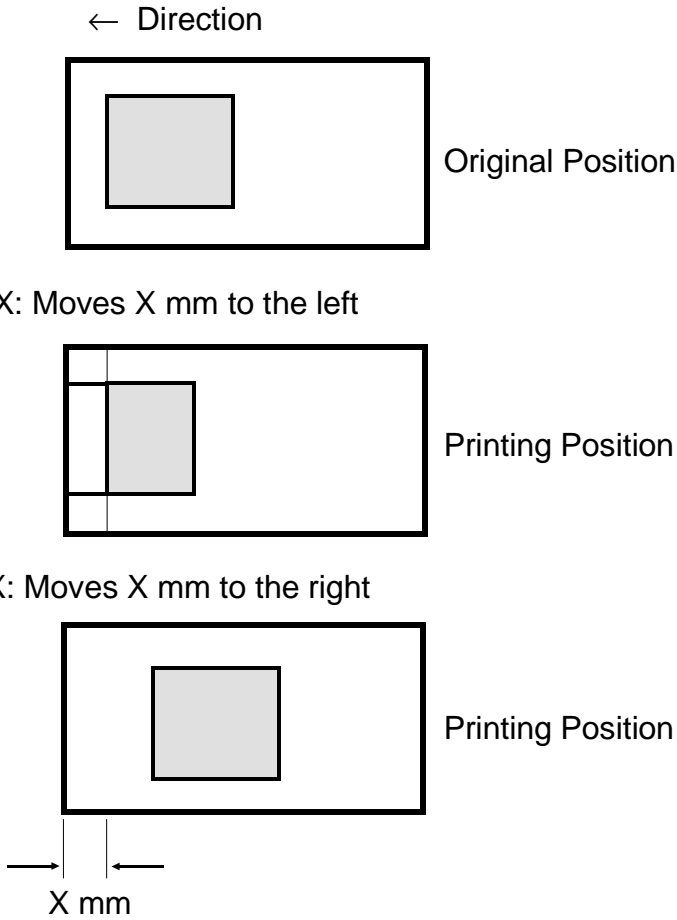

2) SP Mode No. 31 and 37 – SCN/ADF Center Adjust

The printing position moves as shown below.

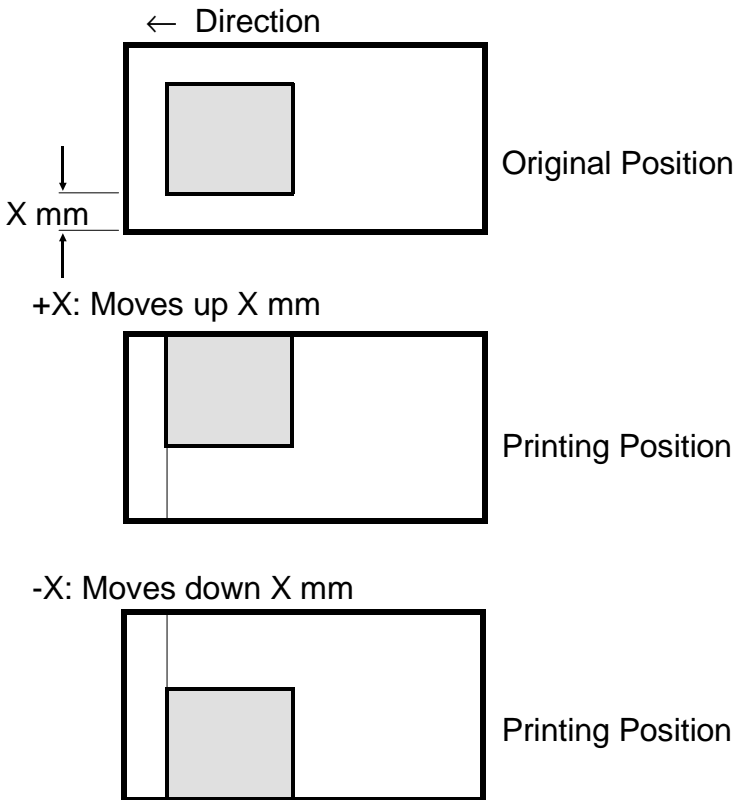

NOTE: When adjusting the scanner image position, input "0" first:
 Example) $X = 0.9 \text{ mm} \rightarrow "0", "9"$, then press the # key.

3) SP Mode No. 88 – Auto Class Mode

In the One Touch Class mode, the machine normally stops when the first print job is finished if the tape marker is not installed.

If "1" is selected in this mode, the machine stops for a while (this interval is the same as when the tape marker is operating). Then it continues with the next print (or master making) job.

4) SP Mode No. 92 – Thermal Paper Mode

You can use this mode to test the thermal head.

Place some thermal paper in the machine face down and change this SP Mode to 1. Place an original on the exposure glass and carry out the master making. The machine starts printing on the thermal paper without doing the master clamp process.

You can also enable SP Mode No. 90 and carry out the master making to test the thermal head without placing an original on the exposure glass.

5) SP Mode No. 95 – Scanner Free Run

- To start the scanner free run, press the Print Start key after selecting "Lamp On/Off" using the # key.
The free run is carried out 6 times faster than the normal speed. (This is the same speed as the scanner returning speed.)
- To stop the scanner free run, press the Stop key. The scanner returns to home position, then stops.
- The machine does not exit SP mode until the scanner returns to home position correctly.

6) SP Mode No. 96 – ADF Original Feed

- It is possible to change the original feed speed by changing the magnification ratio:
65 to 155% (Maximum speed = 65%)
- To start original feed, press the Print Start key after placing originals in the ADF.
Select a magnification ratio before you press the Start key, if you wish to change the original feed speed. The ADF starts feeding until all originals are fed.
- To stop feeding, press the Stop key. The original stops at this moment.
- If the original feed fails, or if the Stop key is pressed, the "A + Jam" indicator turns on.
If the jammed originals are removed from the ADF, the jam indicator turns off and the error is reset.
- The machine does not exit SP mode during feeding.

6.3 INPUT/OUTPUT CHECK MODE

This program checks the electrical components. The procedure for accessing the program is as follows:

Input/Output Check Mode Access Procedure

1. Access the SP mode. (See the SP mode access procedure.)
2. Enter 130 (for the Input Check mode) or 131 (for the Output Check mode) with the **number keys**.
3. Press the **Enter (#) key**.
4. Enter the desired number. (See the Input or Output Check Table.)

NOTE: The number can be shifted up or down by pressing the **Select Size And Direction ("<" or ">") keys**.

5. Press the **Enter (#) key**.

NOTE: In the input check mode, all printing speed LEDs turn on when a sensor or switch that is being tested is actuated. A beep will also be heard.

6. For the Output Check mode, press the **Start key** to turn on the component.
7. Press the **Enter (#) key** to return the display to the initial input or output check menu.
8. Press the **Clear Modes key** to leave the SP mode.

Input Check Table

Code	LCD Display	Component Checked
1.	SN: ADF Cover In- 1	ADF Cover Switch
2.	SN: 1st Original (ADF) In- 2	Document Sensor
3.	SN: 2nd Original (ADF) In- 3	Scan Line Sensor
18.	SN: Paper End In-18	Paper End Sensor
20.	SN: Paper Table Low Limit In-20	Paper Table Lower Limit Sensor
21.	SN: Paper Table Height In-21	Paper Table Height Sensor
23.	SW: Right Cutter In-23	Right Cutter Switch
24.	SW: Left Cutter In-24	Left Cutter Switch
25.	SN: Master Buckle In-25	Master Buckle Sensor
26.	SN: Master End In-26	Master End Sensor
27.	SIG: Ink In-27	When the Ink Detecting Pin detects ink
28.	SIG: Color Drum In-28	When a color drum is installed
31.	SN: Pressure Plate High Position In-31	Upper Pressure Plate Sensor
32.	SN: Pressure Plate Low Position In-32	Lower Pressure Plate Sensor
33.	SW: Master Eject Box In-33	Master Eject Box Switch
34.	SN: Full Master In-34	Full Master Box Sensor
35.	SN: Printing Pressure In-35	Printing Pressure Sensor
36.	SN: 1st Drum Position In-36	First Drum Position Sensor
37.	SN: 2nd Drum Position In-37	Second Drum Position Sensor
38.	SW: Manual Master Cut In-38	Master Cut Switch
39.	SIG: Key Counter In-39	When a key counter is installed
41.	SN: 1st Paper Exit In-41	First Paper Exit Sensor

Code	LCD Display	Component Checked
42.	SN: 2nd Paper Exit In-42	Second Paper Exit Sensor
43.	SN: Master Eject In-43	Master Eject Sensor
45	SN: Scanner Home Position In-45	Scanner Home Position Sensor
47	SN: Platen Set (Scanner) In-47	Platen Cover Switch
51	SN: Plotter Cover In-51	Plotter Cover Safety Switch

Output Check Table

Code	LCD Display	Description
2	MOTOR: ADF Drive Out- 2	Turns on the ADF motor.
3	MOTOR: Master Eject Out- 3	Turns on the master eject motor.
4	MOTOR: Pressure Plate Up/Down Out- 4	Turns on the pressure plate up/down motor.
5	MC: Master Reverse Roller Out- 5	Turns on the master reverse roller magnetic clutch.
6	MOTOR: Vacuum Out- 6	Turns on the vacuum fan motor.
7	MOTOR: Air Knife Out- 7	Turns on the air knife motor.
8	SIG: Key Counter Out- 8	Increments the key counter.
9	COUNTER: Master Out- 9	Increments the master counter.
10	COUNTER: Paper Out-10	Increments the total counter.
12	SOL: Ink Supply Out-12	Turns on the ink supply solenoid.
13	SOL: Drum Lock Out-13	Turns on the drum lock solenoid.
14	SOL: Paper Feed/Print Pressure Out-14	Turns on the paper feed solenoid and the printing pressure solenoid.
15	SOL: Master Feed Clamper Out-15	Turns on the master feed clamper solenoid.
16	SOL: Master Eject Clamper Out-16	Turns on the master eject clamper solenoid.
17	SOL: Master Eject Out-17	Turns on the master eject solenoid.
18	RELAY: Paper Table Down Out-18	Turns on the paper table drive motor (down).
19	RELAY: Paper Table Up Out-19	Turns on the paper table drive motor (up).
20	RELAY: Main Motor Reverse Out-20	Turns the drum in the direction opposite to the printing direction.
21	SIG: Fluorescent Lamp Out-21	Turns on the exposure lamp if the Start key is pressed. Turns off the lamp if the Start key is pressed again.
22	MOTOR: Cutter + Direction Out-22	Turns on the cutter motor (moves it to the rear of the machine).
23	MOTOR: Cutter - Direction Out-23	Turns on the cutter motor (moves it to the front of the machine).
24	MOTOR: Image Shift + Direction Out-24	Turns the image position motor in the "+" direction.

Code	LCD Display	Description
25	MOTOR: Image Shift – Direction Out-25	Turns the image position motor in the "-" direction.
26	MOTOR: Main (10 rpm) Out-26	Turns on the main motor (10 rpm).
27	MOTOR: Main (20 rpm) Out-27	Turns on the main motor (20 rpm).
28	MOTOR: Main (1st Speed) Out-28	Turns on the main motor (1st speed).
29	MOTOR: Main (2nd Speed) Out-29	Turns on the main motor (2nd speed).
30	MOTOR: Main (3rd Speed) Out-30	Turns on the main motor (3rd speed).
31	MOTOR: Main (4th Speed) Out-31	Turns on the main motor (4th speed).
32	MOTOR: Main (5th Speed) Out-32	Turns on the main motor (5th speed).
33	MOTOR: Original Feed Out-33	Turns on the original transport motor.
34	MOTOR: Master Feed Out-34	Turns on the master feed motor.
36	Turn on drum, feed/ pressure SOLs Out-36	Turns on the main motor (10 rpm), the paper feed solenoid, and the printing pressure solenoid.
37	MOTOR: Scanner	Turns on the scanner motor. The scanner moves to the original scanning position for the ADF mode when the Start key is pressed. It returns to home position when the Start key is pressed again.
41	SIG: VHD on Out-41	Applies thermal head voltage. Power is applied by pressing the Start key. It is stopped by pressing the Start key again.

7. TEST PATTERN IMAGE MODE

This function is used to determine which printer component is causing an image problem on the master.

In this mode, the background pattern that is printed covers the entire sheet of paper.

Procedure

1. Place paper on the paper table.

NOTE: To reduce thermal head load, use the smallest paper size possible, i.e. the smallest paper width on which the part with the image problem can be printed.

2. Access SP mode.
3. Input No. 90 and enter "1". Then, press the **Enter (#) key**.
4. Press the **Clear Modes key** to leave the SP mode.
5. Carry out the master making process (an original is not necessary).
6. Make some prints and check the image.

NOTE: The SP mode No. 90 setting returns to the default (0) after the above procedure.

Assessment

If the printout is normal, a Part A component is defective.

If the printout is abnormal, a Part B component is defective.

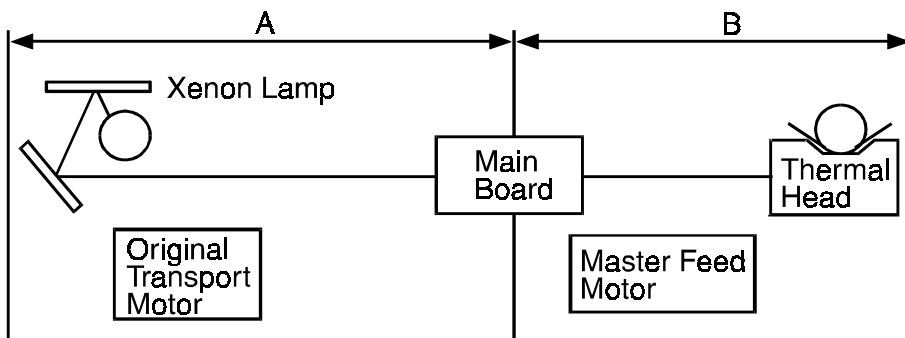

NOTE: This mode can be used in combination with SP mode No. 92, Thermal Paper Mode.

8. USER CODE MODE

8.1 USER CODES

With the user code function (SP mode No. 120), operators must input an authorized code before the machine will operate. The machine keeps track of the number of prints made under each code.

There are 20 user codes as follows:

No.	User Code No.
1	382
2	191
3	182
4	173
5	164
6	155
7	146
8	137
9	128
10	119
11	482
12	291
13	282
14	273
15	264
16	255
17	246
18	237
19	228
20	219

8.2 HOW TO USE A USER CODE

1. Enter the user code (3 digits) with the **number keys**.
2. Press the **Enter (#) key**.
3. Press the **Start key** to start printing.

NOTE: The user code mode is reset if the **Clear Modes key** and the **Stop key** are pressed together.

9. AVAILABLE OPTION/SUPPLY TABLE

O: Standard combination

Δ: Usable under certain conditions

X: Cannot be used

		C215/C216/ C224/C226
Masters	Type 800	X
	Type 900	X
	VT-S	X
	VT-M	X *NOTE1
	VT-L	X
	VT-II-M	O
Inks	Black	O
	Color (rd/bl/gn/br)	O
	VT-Black-1000	X
Color Drums	Color Drum	Δ *NOTE2
	Color Drum Type 905	Δ *NOTE2
	Color Drum VT2000-M	O
	Color Drum VT2000-LG	X *NOTE3
	Color Drum VT2000-S	X *NOTE3
	Color Drum VT3000-L	X
	Color Drum VT3000-S	X
Others	Cassette B4	X
	Cassette VT3000-L	X
	Cassette VT3000-S	X
	Tape Marker Type 20	O
	Priport Table	O
	Priport Table VT3000	X

- NOTE:** 1) The VT-M master can be installed on the C215/C216/C224/C226, however, a weak image (sometimes image blank) will appear. This is because the VT-II-M master is more sensitive than the VT-M master.
- 2) The modified master clamber (P/N C2194948) must be installed.
- 3) The drum can be installed, however, the maximum image area is limited according to the drum screen size.

SECTION 5
REPLACEMENT
AND
ADJUSTMENT

1. EXTERIOR

1.1 ADF

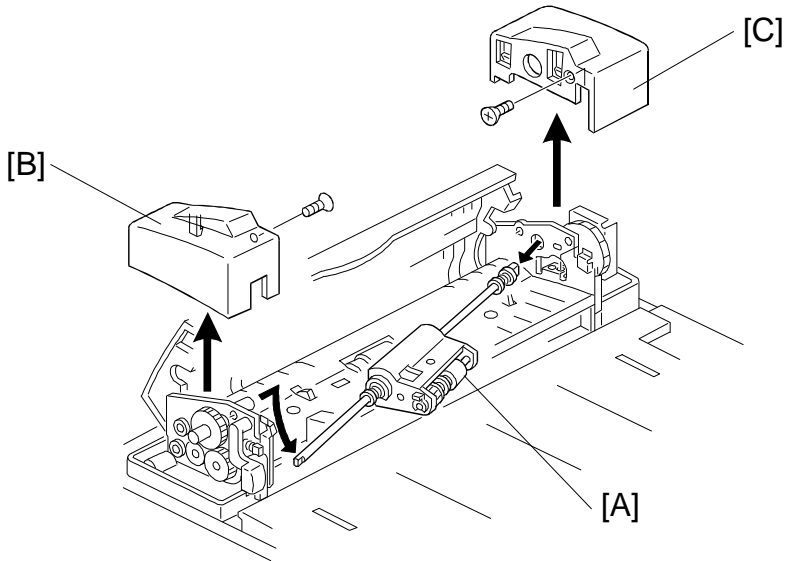

First, remove the ADF roller assembly [A].

A: ADF Roller Assembly

B: ADF Upper Front Cover (1 screw, 1 hook)

C: ADF Upper Rear Cover (1 screw, 2 hooks)

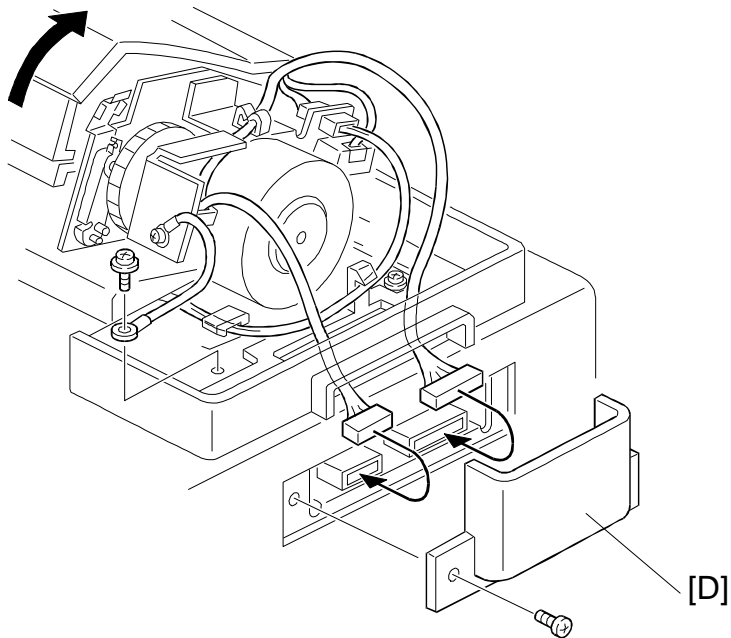

Remove the connector cover, then remove the harness and a ground wire.

D: Connector Cover (1 screw)

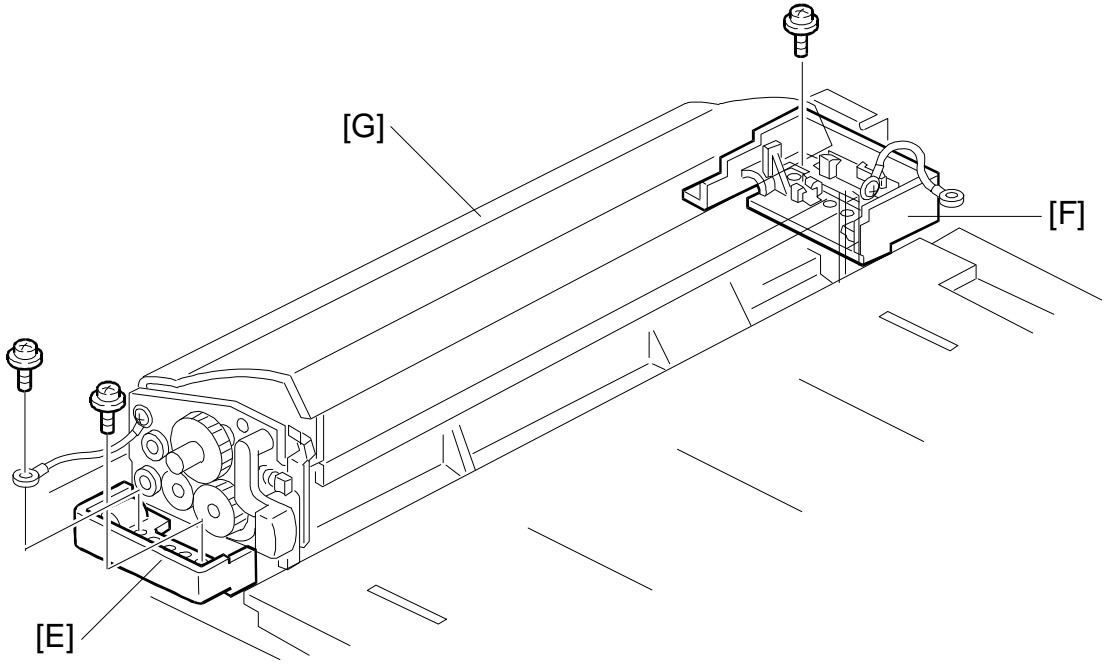

- E: ADF Lower Front Cover (2 screws, 1 grounding wire)**
- F: ADF Lower Rear Cover (2 screws, 1 grounding wire)**
- G: ADF Unit (2 connectors)**

1.2 OPERATION PANEL

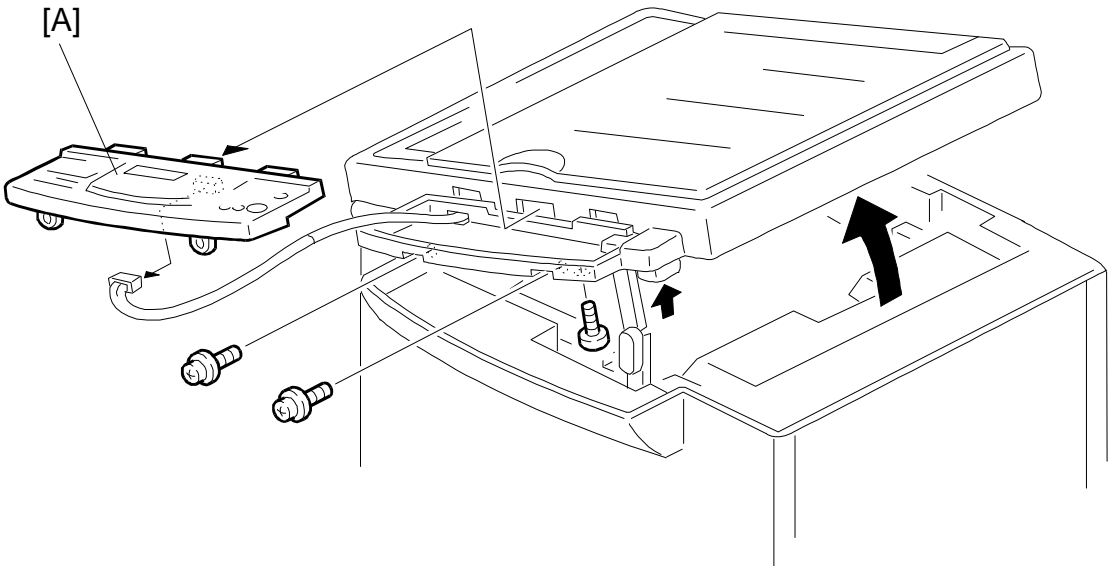

- A: Operation Panel Assembly (2 tapping screws)**

1.3 PLATEN COVER AND UPPER COVERS

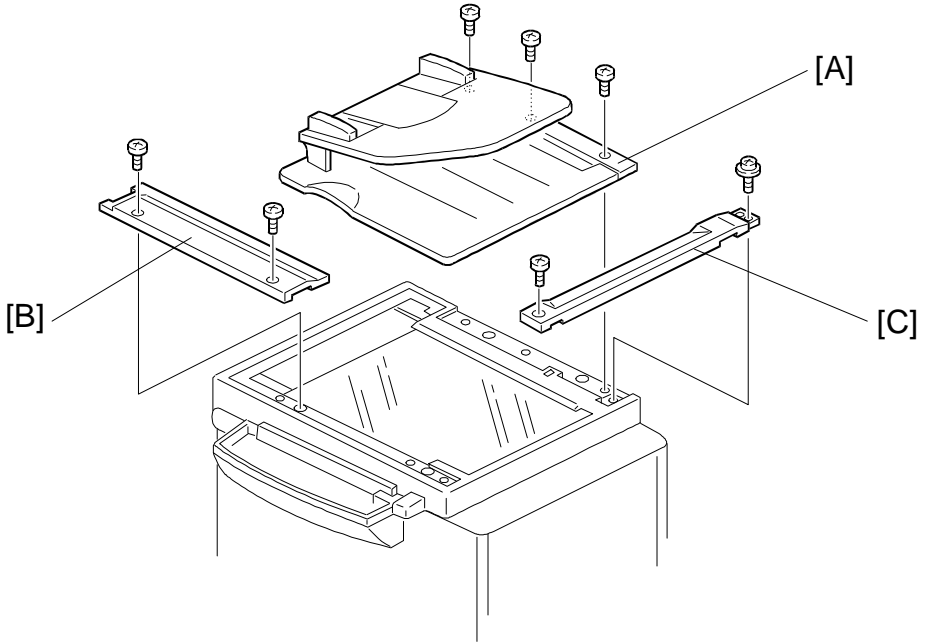

- A: Platen Cover (3 tapping screws)**
- B: Horizontal Upper Cover (2 silver screws)**
- C: Vertical Upper Cover (1 silver screw, 1 screw)**

1.4 TOP COVER AND EXPOSURE GLASS

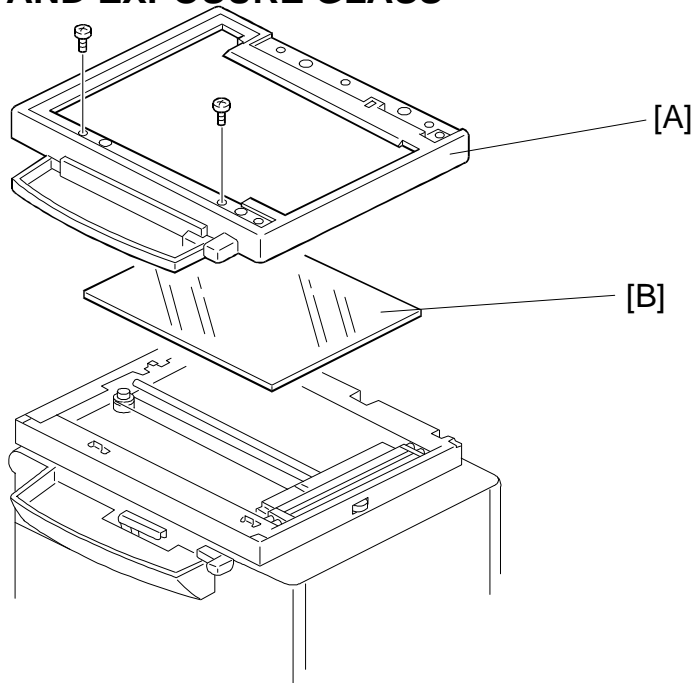

- A: Top Cover (2 screws)**
- B: Exposure Glass**

Replacement
Adjustment

1.5 OTHER COVERS

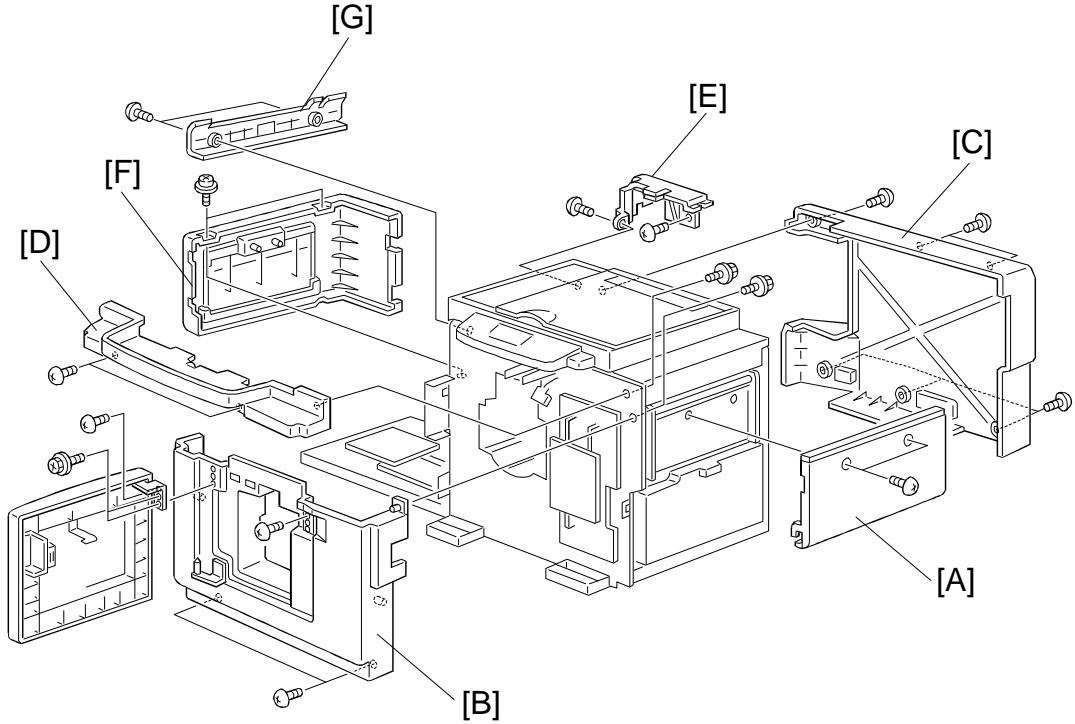

A: Master Feed Unit Cover (2 screws)

B: Front Cover (4 screws)

- Open the front door to remove the front screws

C: Rear Cover (6 screws)

D: Operation Panel Under Cover (2 screws)

E: Rear Left Cover (2 screws)

F: Master Eject Cover (2 screws)

G: Left Upper Cover (2 screws)

2. ORIGINAL FEED SECTION

2.1 ADF ROLLER ASSEMBLY AND COVERS

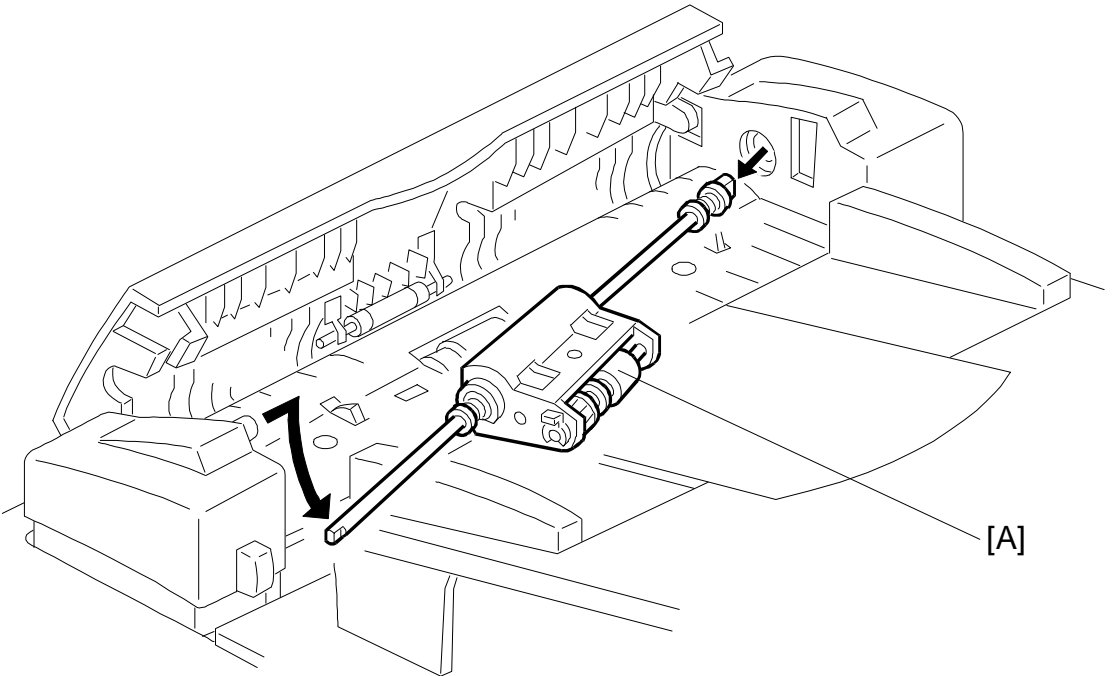

A: ADF Roller Assembly

2.2 PICK-UP ROLLER

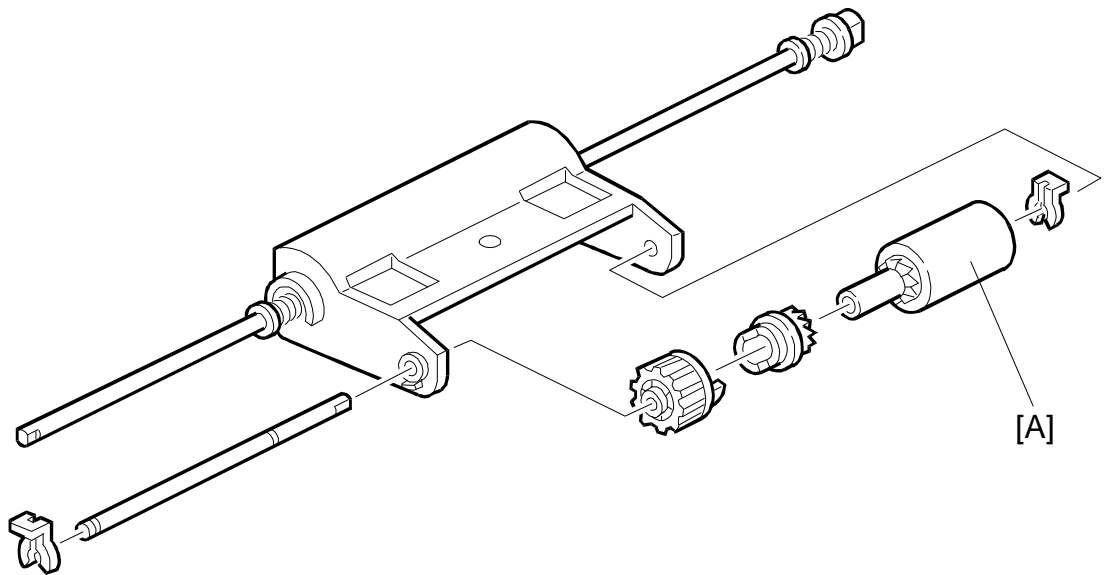

A: Pick-up Roller (2 clips, 2 gears)

2.3 FEED ROLLER

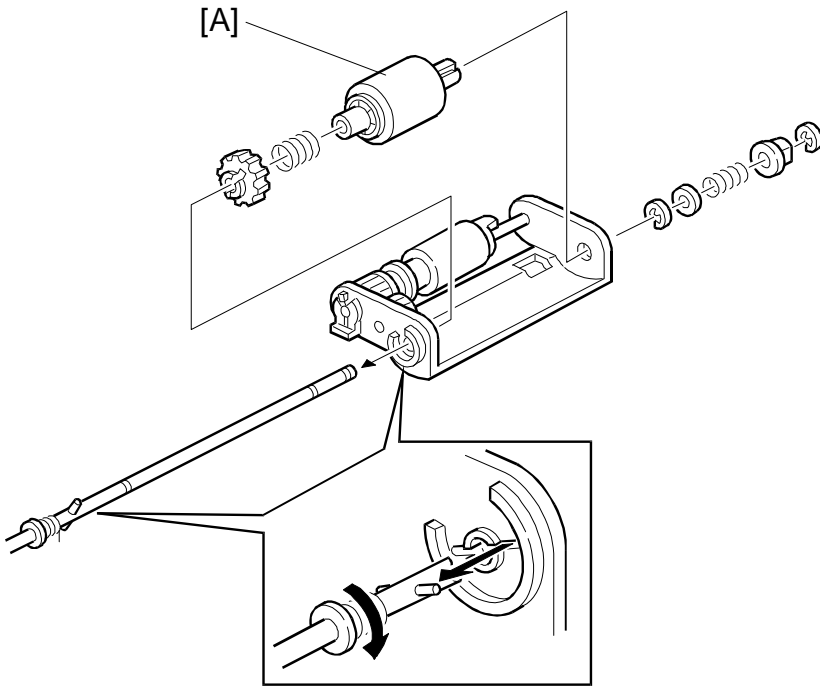

A: Feed Roller (1 clip, 1 gear, 2 springs, 2 E-rings, 1 washer)

2.4 SEPARATION ROLLER

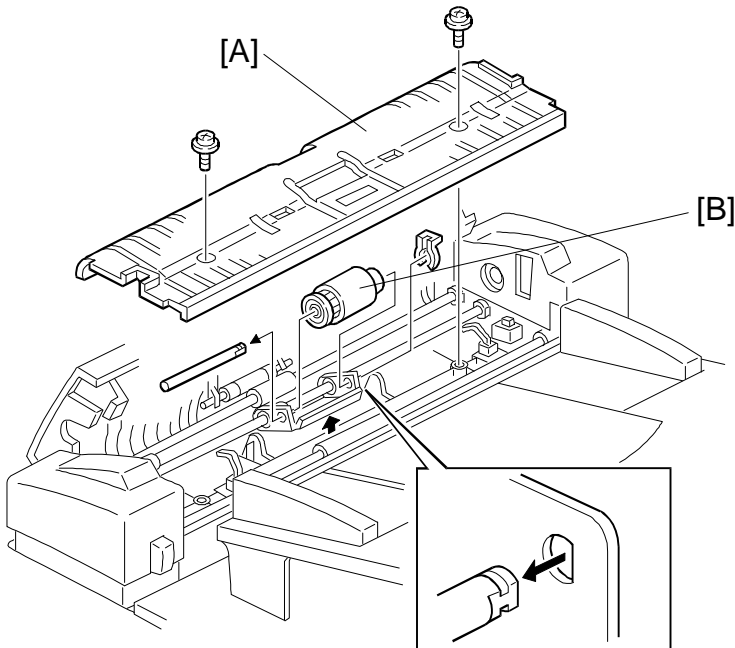

A: Upper Guide Plate (2 tapping screws), B: Separation Roller (1 clip)

2.5 ADF MOTOR AND COVERS

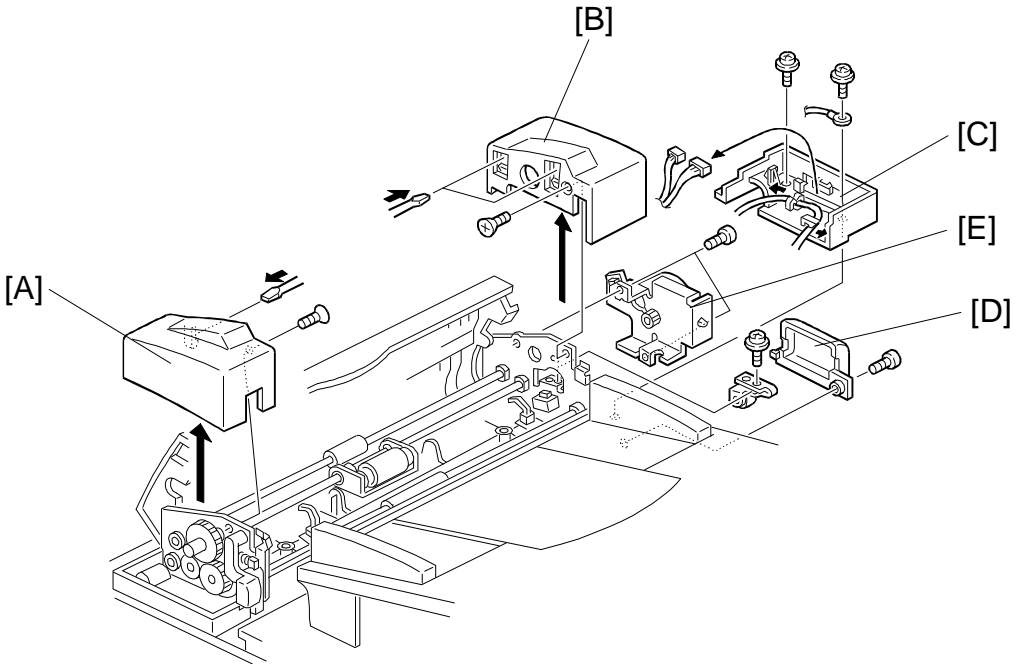

- A: ADF Upper Front Cover (1 screw, 1 hook)**
- B: ADF Upper Rear Cover (1 screw, 2 hooks)**
- C: ADF Lower Rear Cover (2 screws)**
- D: Connector Cover (1 screw)**
- E: ADF Motor (2 screws)**

2.6 R0 AND R1 ROLLERS

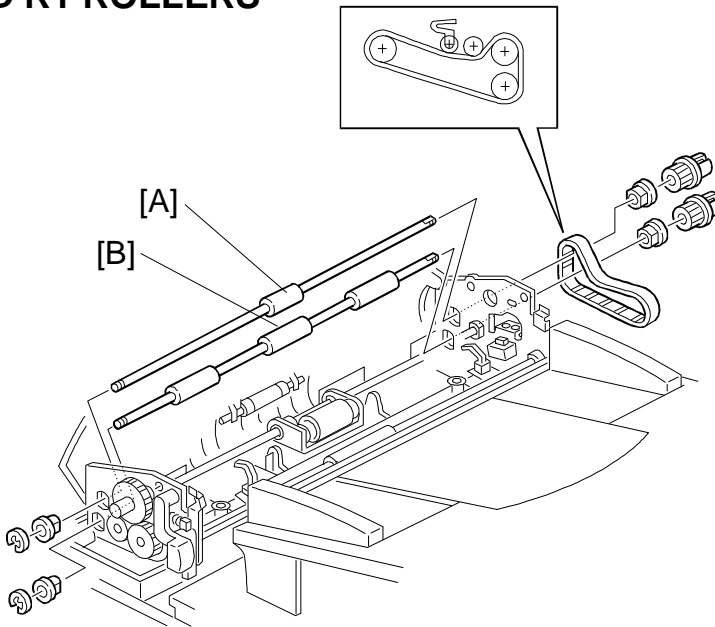

- A: R0 Roller (1 E-ring, 1 gear, 2 bushings)**
- B: R1 Roller (1 E-ring, 1 gear, 2 bushings)**

2.7 R2 ROLLER

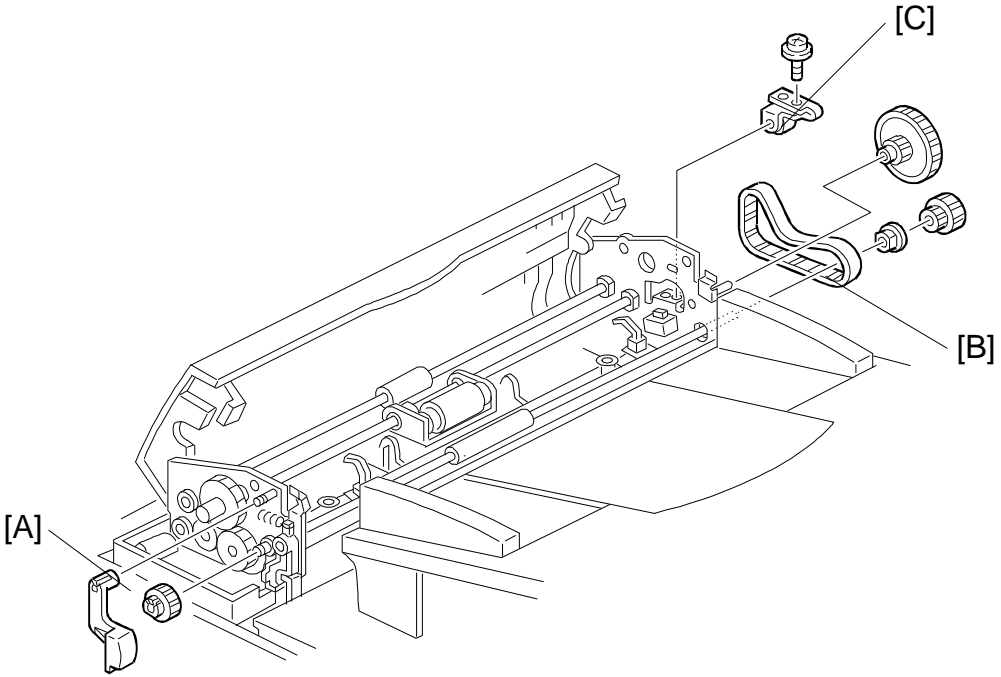

- A: ADF Release Lever**
- B: Timing Belt**
- C: Tensioning Roller Ass'y (1 screw)**

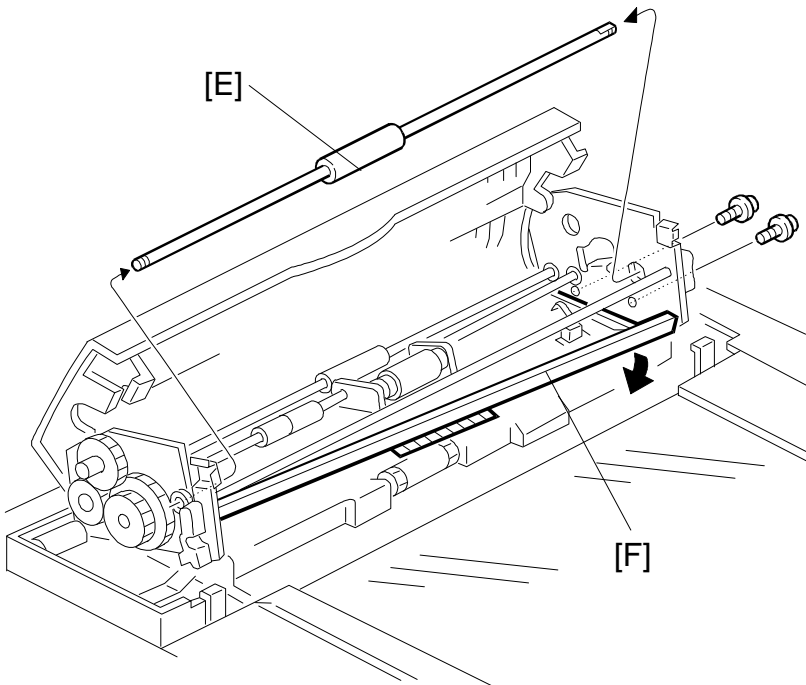

Remove the R2 roller [E] while lowering the guide plate [F].

2.8 DOCUMENT SENSOR

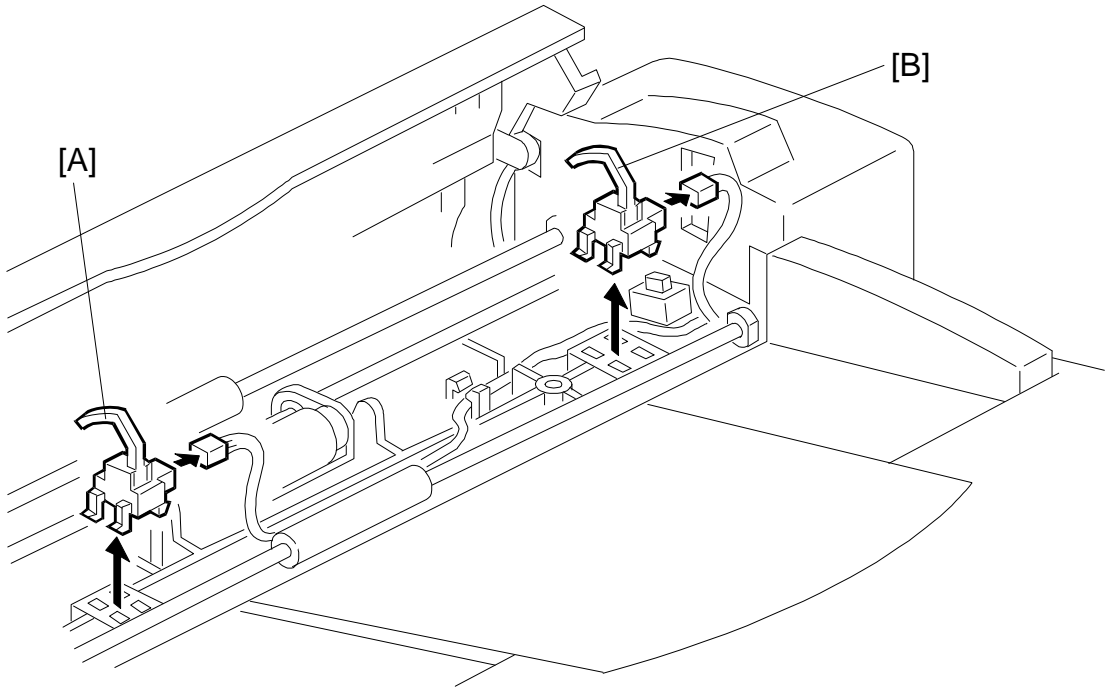

- A: Document Sensor
- B: This sensor has no function.

2.9 SCAN LINE SENSOR

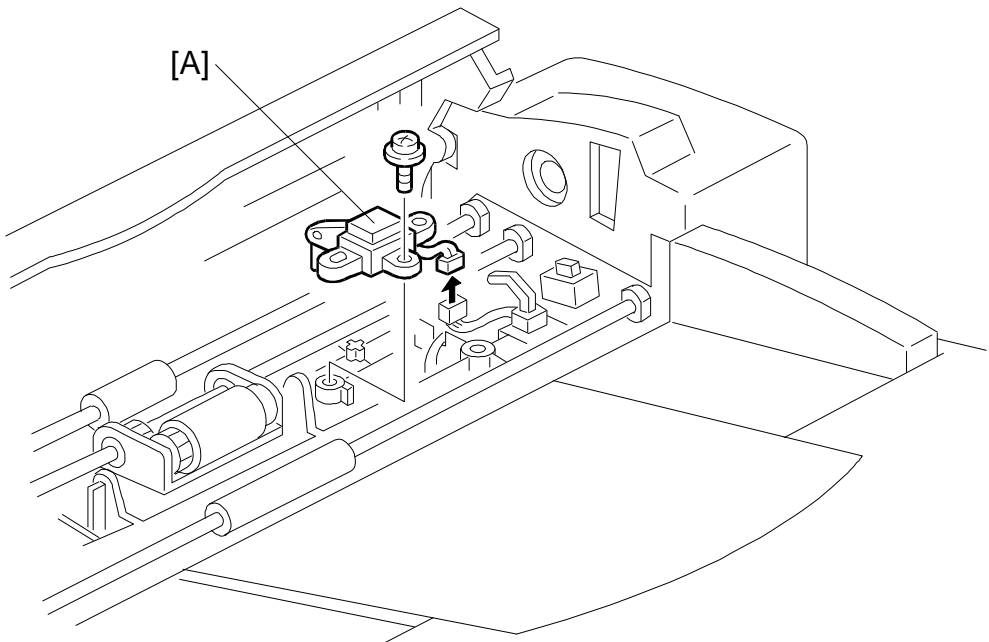

- A: Scan Line Sensor (1 screw)

Replacement
Adjustment

2.10 COVER SENSORS

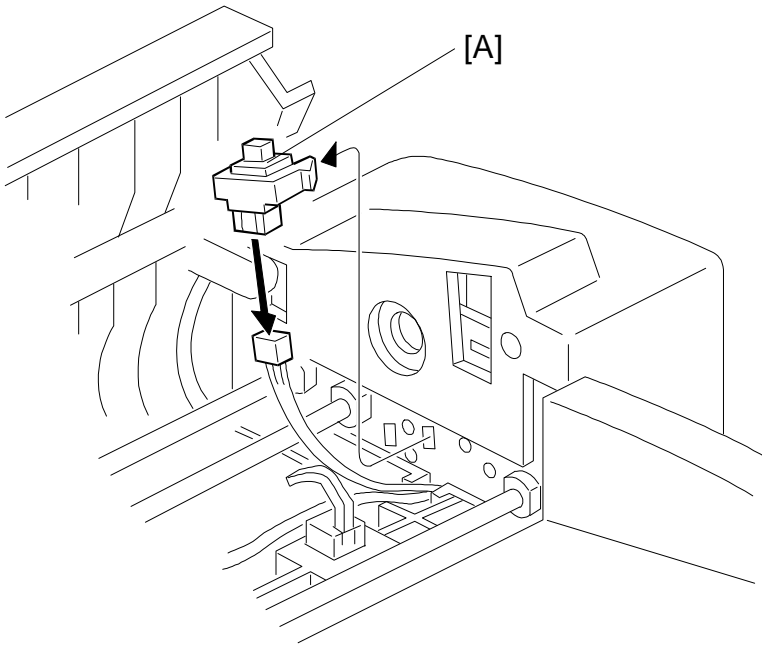

A: ADF Cover Switch

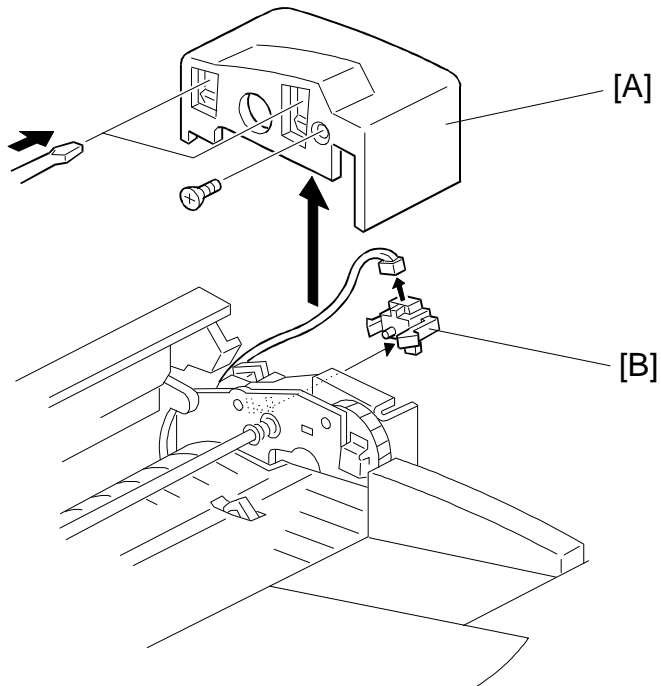

A: Upper Rear Cover (1 screw, 2 hooks)
B: ADF Switch

3. SCANNER SECTION

3.1 CONTACT IMAGE SENSOR

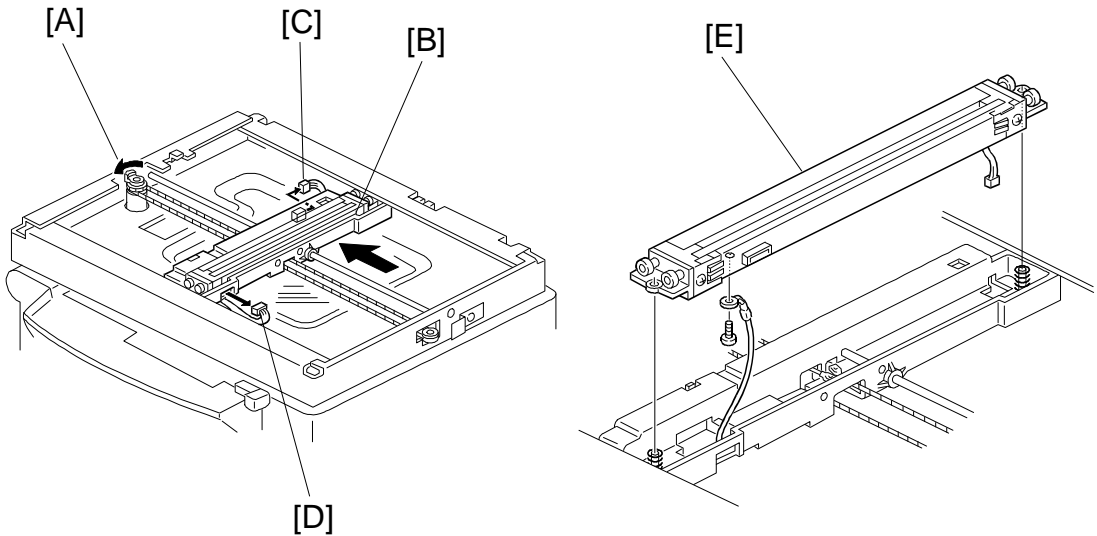

Turn the gear [A] anti-clockwise to move the image sensor [B] to the middle of scanning path.
Then disconnect harnesses [C] and [D].

E: Contact Image Sensor Assembly
(1 tapping screw, 1 grounding wire)

Note for the scanner guide shaft replacement

If you replace the scanner guide shaft, put Launa Oil 40 on all surfaces of the shaft (P/N: 54429103 - Launa Oil 40).

3.2 FLUORESCENT LAMP STABILIZER

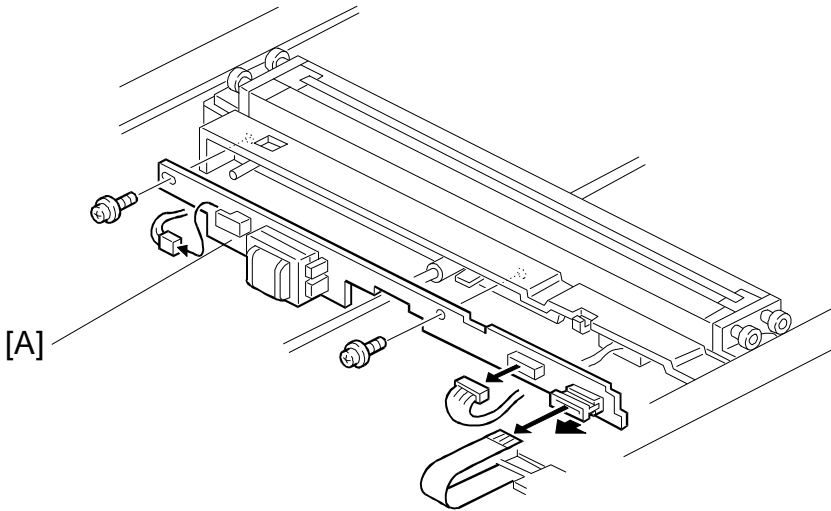

A: Fluorescent Lamp Stabilizer (2 tapping screws, 3 connectors)

3.3 PLATEN COVER AND SCANNER HOME POSITION SENSORS

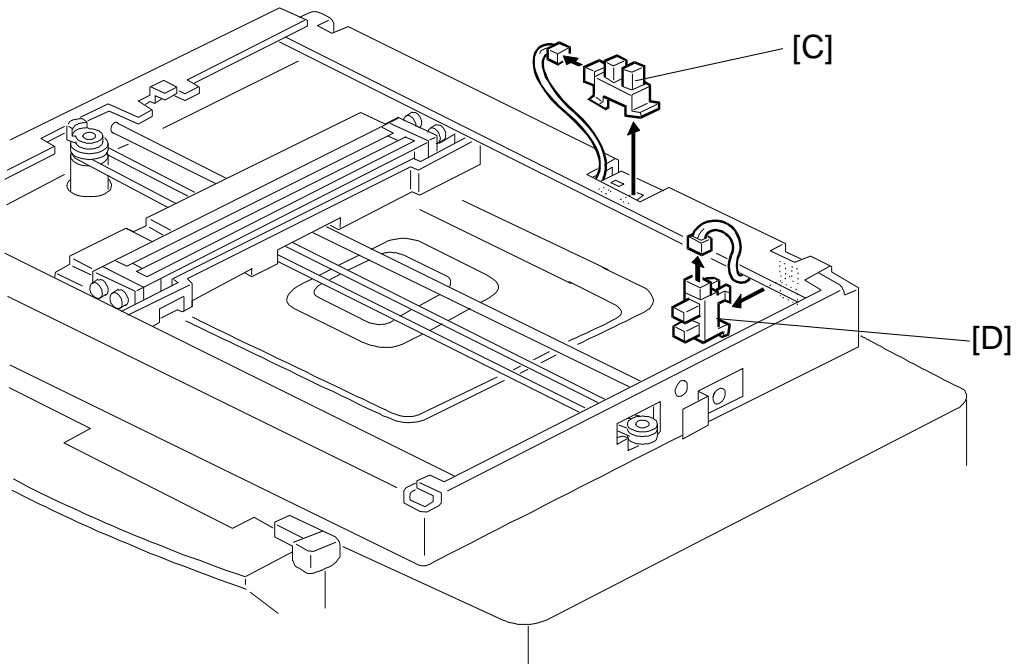

C: Platen Cover Sensor (1 connector, 3 hooks)

D: Scanner Home Position Sensor (1 connector, 3 hooks)

3.4 SCANNER MOTOR

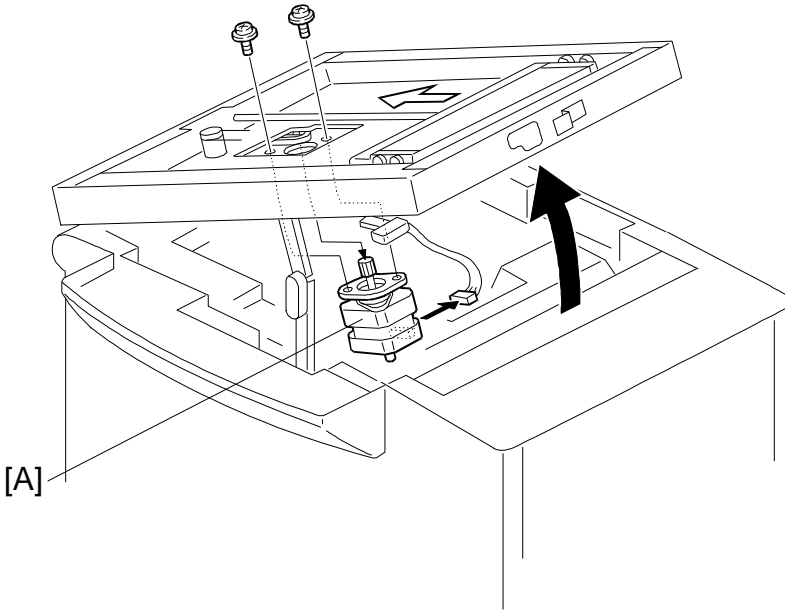

A: Scanner Motor (2 screws, 1 connector, 1 timing belt)

3.5 IMAGE MAGNIFICATION ADJUSTMENT (IN THE SUB-SCAN DIRECTION)

Adjust the magnification ratio in the sub-scan direction using SP mode No. 30 so that the printed image length is $100\% \pm 0.5\%$ compared with the original image length. If the optional ADF is installed, use SP mode No. 36 for the ADF mode, also.

Platen Mode Sub-scan Magnification Adjustment	SP mode No. 30
ADF Mode Sub-scan Magnification Adjustment	SP mode No. 36

4. MASTER FEED SECTION

4.1 THERMAL HEAD VOLTAGE ADJUSTMENT

Purpose: To maintain master making quality and extend the lifetime of the thermal head.

NOTE: This adjustment is always required when the thermal head or power supply board is replaced.

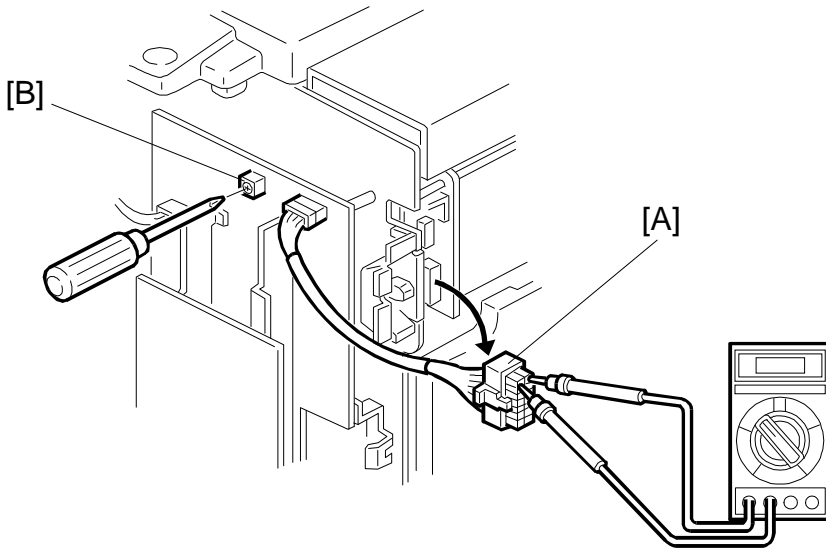

1. Remove the rear cover and the right cover of the machine.
2. Disconnect the connector [A] from the plotter unit.
3. Check the voltage noted on the decal located on the thermal head.
(The voltage is different for each thermal head.)
4. Access "I/O Check Mode".
 - SP mode No. 131, then Output Check mode 41.
5. Press the Start key to apply the thermal head voltage.
6. Confirm that the voltage between one of the VHD terminals and one of the ground terminals of CN503 is at the level specified on the decal
(Within + 0 V, - 0.1 V).
7. If it is not, adjust VR1 [B] on the power supply board.

NOTE: Press the Stop key to stop applying the thermal head voltage.
Do not keep the thermal head voltage on for a long period.

<< POINT-TO-POINT DIAGRAM (C226) >>

